CATALOG

ReliaGear® neXT

UL 67 low-voltage distribution
power panelboards



In our ongoing commitment to offer superior value at every touchpoint, from ordering to installation to maintenance, we have combined the best technology of ABB to bring you a true breakthrough in power panels.

Table of contents

01. General characteristics	4
02. Panelboard details	16
03. Molded case circuit breakers	32
04. Panelboard selection guide/ numbering system	54

—

01

General characteristics

General characteristics

General characteristics	
Features and benefits	06
Applications	12
Standards and certifications	14

Install components in seconds Instill confidence for a lifetime

—
01 Improved finger-safe bus stack that meets IP20 standards in select models

—
02 Spring-loaded circuit breaker plug-in connectors

—
03 Bus stack can be flipped 180 degrees



EASY TO INSTALL

Modular, flexible, fast.

The ReliaGear neXT features a field-reversible bus stack that can be flipped 180 degrees to accommodate top or bottom feeds without extra parts. Ground and neutral locations are also field-swappable. These advantages plus plug-in, single-tool simplicity enable easy, fast component installation or replacement in the field. For even greater flexibility, circuit breakers can be installed anywhere on the bus stack.



OUTSTANDING RELIABILITY

Dependable connections.

Spring-loaded circuit breaker plug-in connectors with increased plating thickness for durability withstand repeated insertion and removal. Levering features further reduce installation and removal force. This plug-in connector design uses the magnetic forces generated by a short circuit to help make the connection even tighter and more reliable. There are fewer bolted joints that can become loose or require torque checks.



ENHANCED SAFETY FEATURES

The next level of protection.

ABB is passionate about safety. From the largest piece of arc-resistant switchgear down to the smallest arc fault and ground fault sensing circuit breaker, ABB is always designing ways to help keep personnel out of harm's way. ReliaGear neXT panelboard and switchboard designs come with an improved finger-safe bus stack that meets IP20 standards. Thanks to the breaker-integrated Bluetooth® technology, it is also possible to set parameters and check measurements directly from your smartphone from an arc-free zone.



01

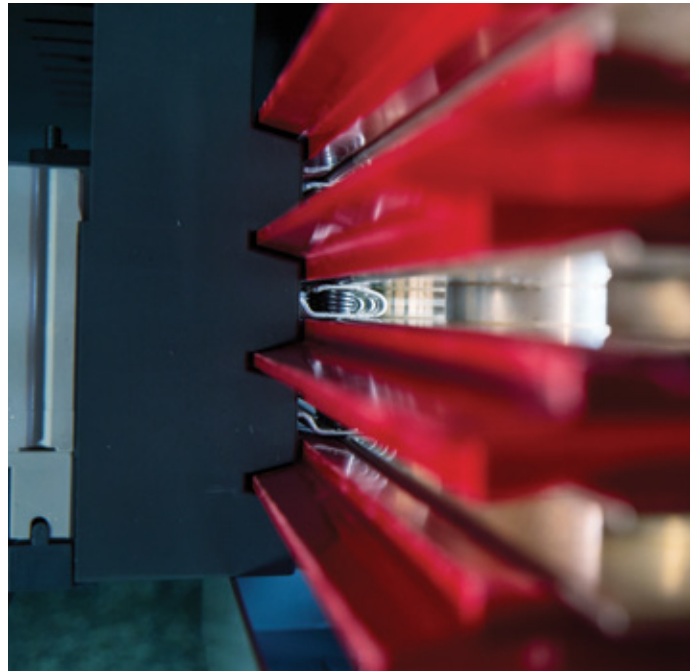

02

01 Improved finger-safe bus stack that meets IP20 standards in select models.

02 Spring-loaded circuit breaker plug-in connectors.

03 Bus stack can be flipped 180 degrees.

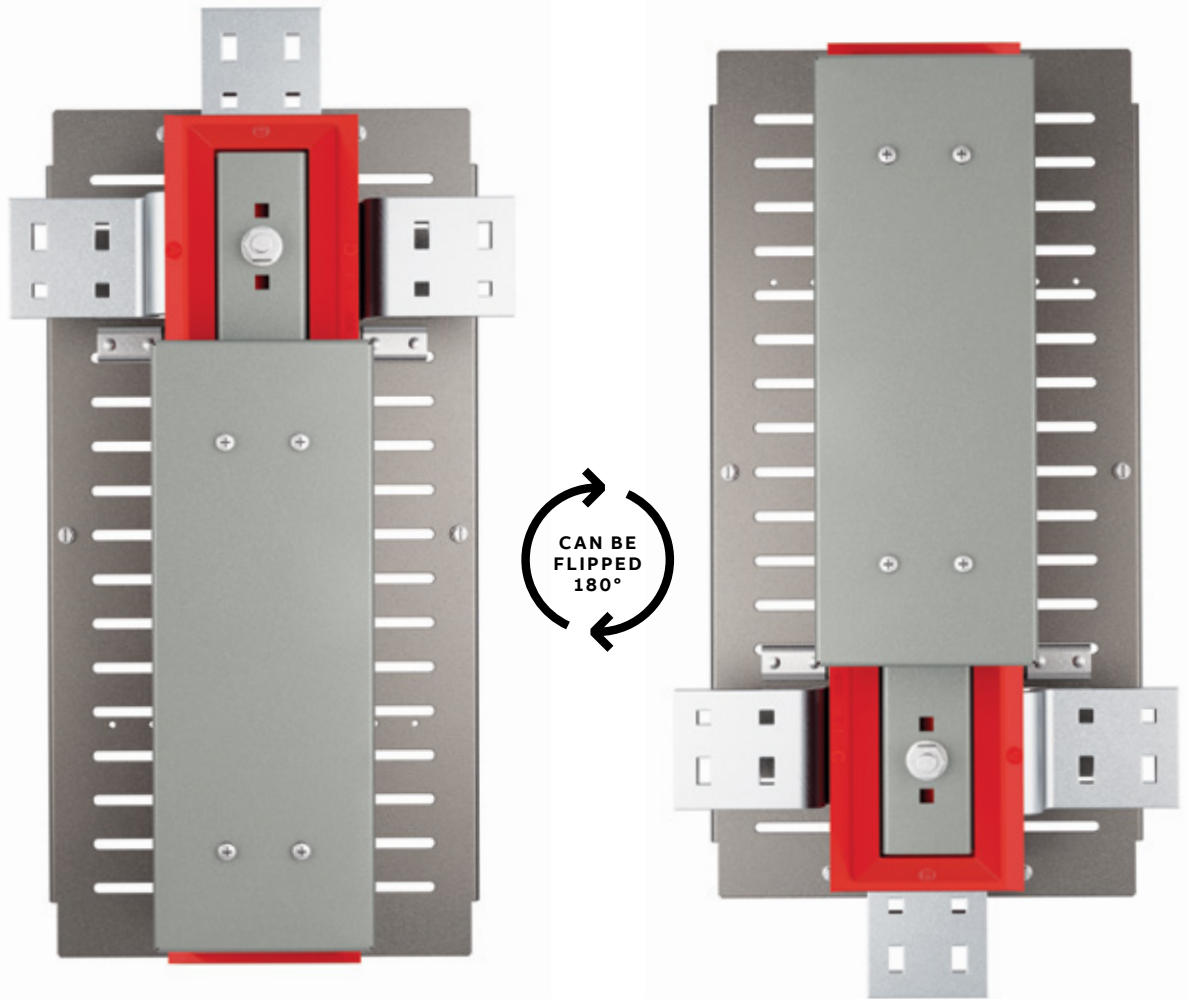

03

Tmax[®] XT plug-in circuit breakers feature spring-loaded primary disconnects, enabling fast installation, easy replacement and reliable connection to maximize your uptime.

A close-up photograph of Tmax XT plug-in circuit breakers. The image shows a red safety handle in the foreground, partially obscuring the view of the breakers. The breakers are mounted on a metal rail, and their spring-loaded primary disconnects are visible. The background is dark and out of focus, emphasizing the mechanical details of the breakers.

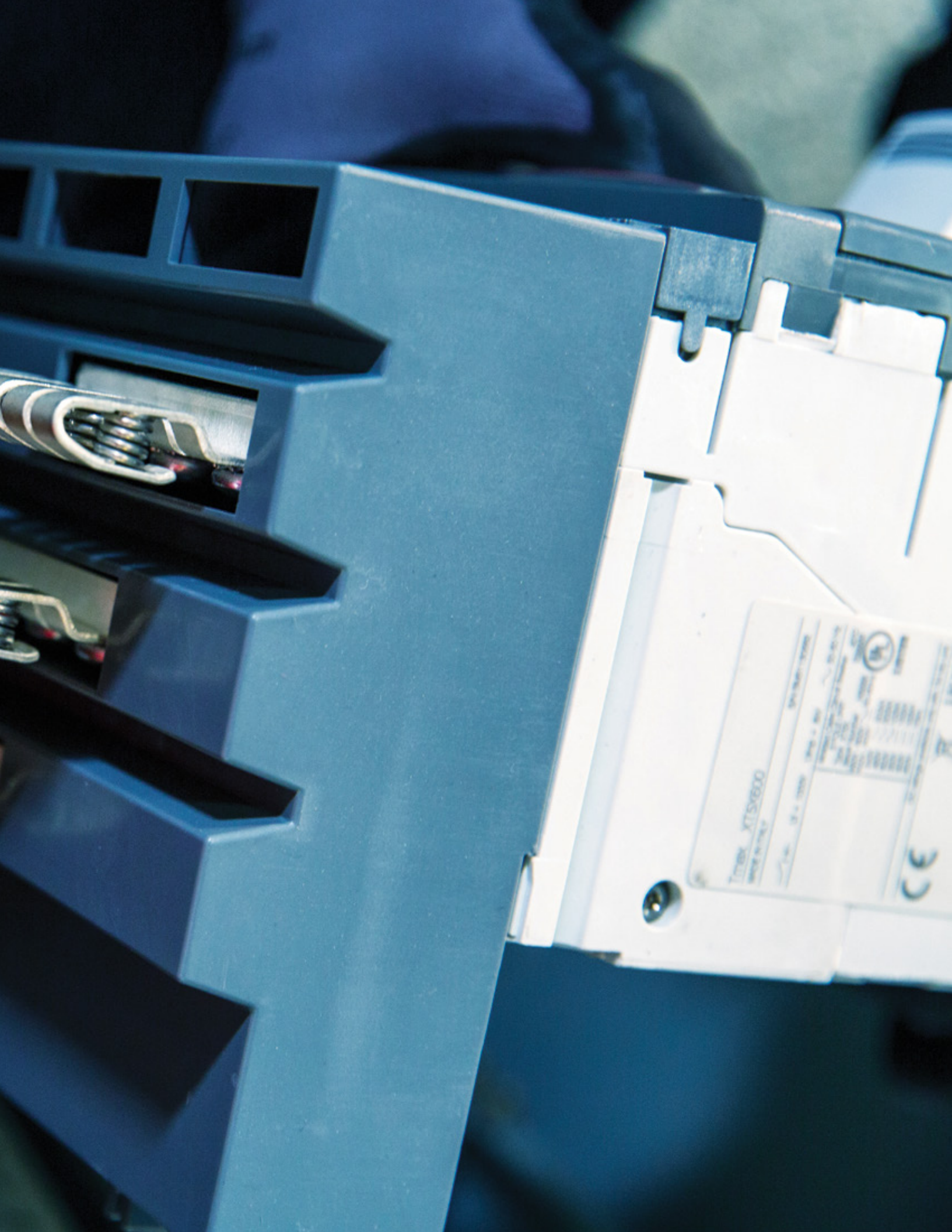

T1000 - XT51600
MADE IN CHINA

SPECIFICATIONS	
Model	T1000 - XT51600
Part No.	1000-51600
Weight	1.2 kg
Dimensions	100 x 100 x 100 mm
Power	5V DC
Current	100 mA
Operating Temp.	0°C to 40°C
Storage Temp.	-20°C to 60°C
Humidity	10% to 90% RH
Shock	10g
Vibration	0.5g

CE

Even more advantages

—
01 Components can be installed in as little as 20 seconds
—

02 Remote access to accurate information anywhere, anytime



REDUCED COSTS

Speed up your project.

Reducing labor and saving time is crucial for electrical contractors. In fact, an 8% savings in labor costs for a typical large project can mean 133% more profit for the contractor.* ReliaGear neXT's intuitive single-person installation enables components to be installed in as few as 20 seconds, dramatically saving skilled-labor costs, reducing downtime and lowering the risk of mistakes.

*From "How to Make a Good Estimate Even Better" by Don Kiper, EC&M, 2017.



ADVANCED CONNECTIVITY

Link to data analysis in real time.

With ABB Ability® cloud connectivity, multiple communication options and built-in metering, the Tmax XT circuit breakers of ReliaGear neXT put facility managers in control. The extreme precision of the data measured means users have access to accurate information anywhere, anytime, making it easier to monitor resources and identify savings opportunities.



ORDERING AND LOGISTICS

Easy to stock.

With ReliaGear neXT, you have a single catalog number for all circuit breaker installation kits, convenient ordering with the **empower** configurator tool and Merchandised SuperBox options for quick deliveries. Power panels are available unassembled or with factory-assembled interior.



01

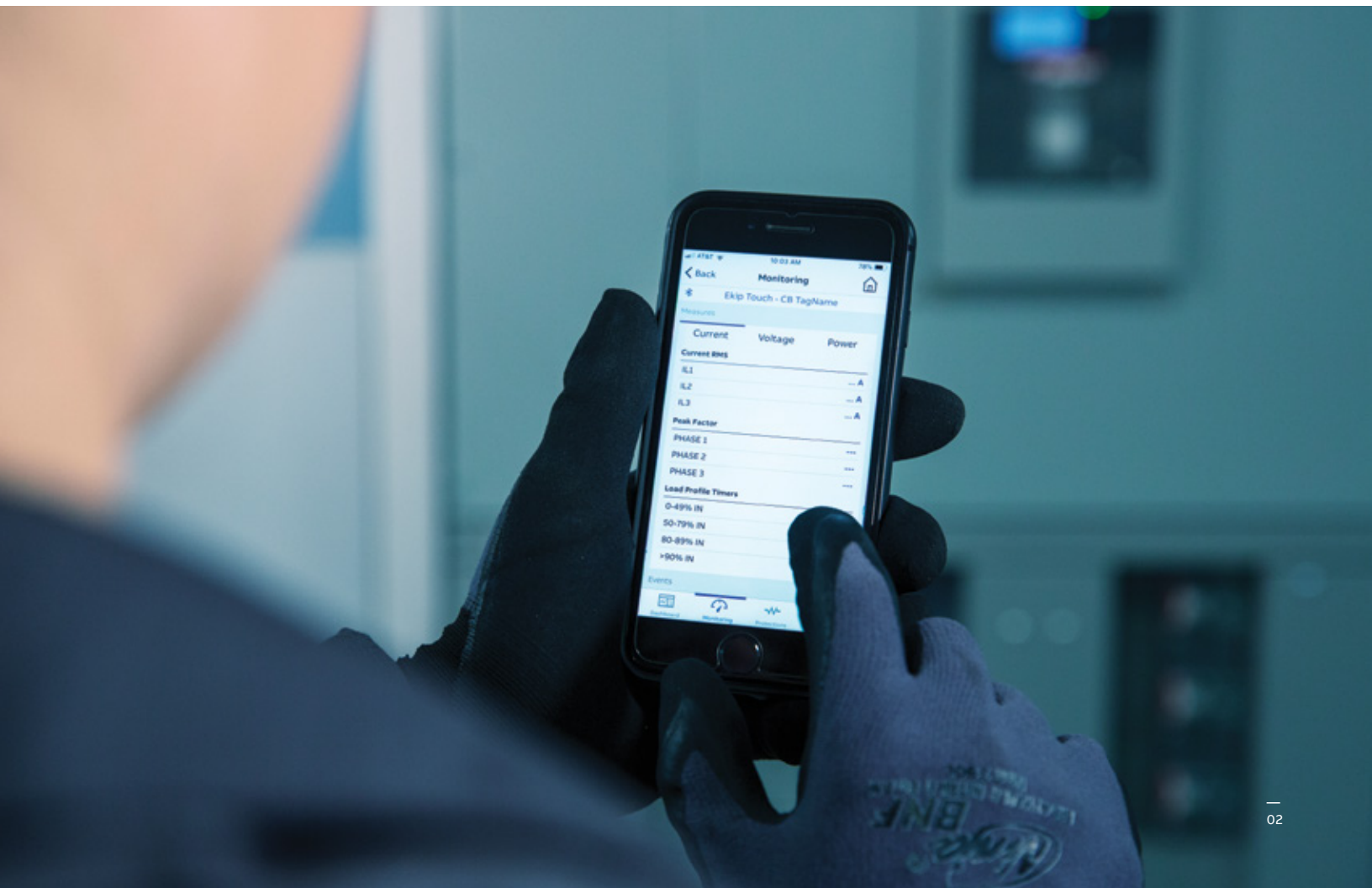

02

Take your performance to the neXT level.

ReliaGear neXT — a go-to power panel for professionals looking to gain the competitive edge

Contractors

For contractors, time is money. And traditional bolt-on power panels that require highly skilled labor and take hours to install or modify in-field can cost you big. But now there's ReliaGear neXT. It works harder, so you don't have to.

Distributors

Smart, optimized, simplified design helps distributors maximize stock inventory. The user-friendly and intuitive **empower** tool minimizes the configuration process time by providing product drawings, bills of materials and technical documentation.

Consultants and engineers

ReliaGear neXT adds value to any job, giving consultants the power to influence customer specifications, helping to make life easier, providing safety features for installers and significantly reducing downtime for end users. The broad offering allows ABB to provide the right product for the right application.

OEMs and panel builders

Versatility, easy installation and performance make ReliaGear neXT a perfect match for quality panels and any type of equipment.

Facility managers

ReliaGear neXT enables fast component installation or replacement, reducing downtime and cost. And its connectivity helps managers monitor resources and identify savings opportunities.

ReliaGear neXT is ideal for small to large projects and any application where speed, reliability and performance matter:

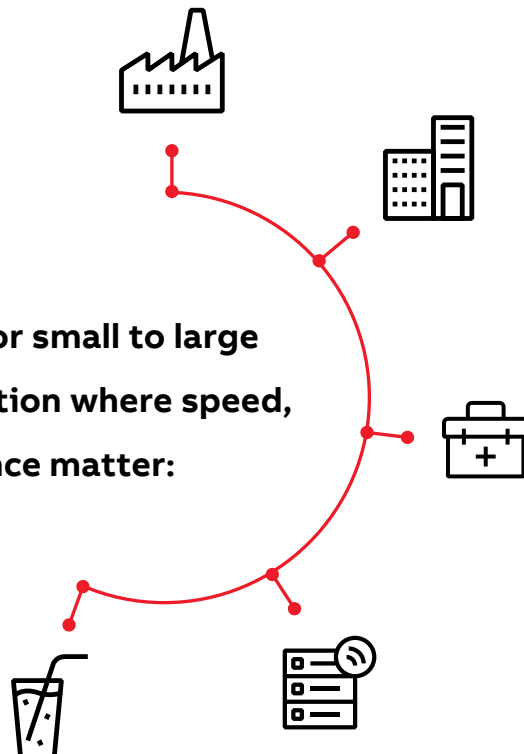

- Industrial complexes
- Commercial buildings
- Residential developments
- Health care facilities
- Data centers
- Food and beverage facilities
- Infrastructure projects
- And more



General characteristics

Standard and certifications

The low-voltage power panelboards and protection devices in this specification are designed and manufactured according to the latest revision of the following standards (unless otherwise noted):

- ANSI/NEMA PB 1, panelboards
- ANSI/NFPA 70, National Electrical Code
- UL 489, molded case circuit breakers
- CSA 22.2 No. 5-13, molded case circuit breakers
- UL 50, enclosures for electrical equipment
- UL 67, panelboards
- UL 98, enclosed and dead front switches
- cUL listing low-voltage modular power panels
- Seismic certification according to ICC-ES AC156
- ABS product type approval certification:
23-2430464-PDA-DUP

—

02

Panelboard details

Panelboard details

Panelboard details	
Introduction	18
Enclosures	19
Bus stack	20
Interior frame	21
Fronts, gutter doors, blanks and fillers	22
Door-in-door option	23
Full IP20 finger-safe	24
Panelboard configurations	25
Installation technical data	26
Accessories	27–30

Panelboard details

Introduction

The ReliaGear neXT power panelboard can be equipped with circuit breakers from 15 A to 1200 A. The maximum short-circuit rating is equal to 200 kAIC at 240 V, 200 kAIC at 480 V or 100 kAIC at 600 V, or the lowest current interruption rating of any device installed, except as noted in the series rating listed with an integral or remote main breaker or fusible switch installed ahead of the power panel. DC ratings are also available. See pages 34 and 44 for more details.

ReliaGear neXT power panelboards can be used on the following system voltages:

- 240 V AC; 3-phase, 3-wire
- 480 V AC; 3-phase, 3-wire
- 600 V AC; 3-phase, 3-wire
- 208Y/120 V AC; 3-phase, 4-wire
- 480Y/277 V AC; 3-phase, 4-wire
- 600Y/347 V AC; 3-phase, 4-wire
- 240/120 V AC Delta hi-leg; 3-phase, 4-wire
- 120/240 V AC; 1-phase, 3-wire
- 125 V DC; 2-wire
- 250 V DC; 2-wire



Panelboard details

Enclosures

Enclosures

The ReliaGear neXT panelboard is offered in 12 enclosure size configurations, with three different widths (30", 40", 45") and four different heights (60", 72", 84", 96"). These configurations simplify design and maximize stock inventory. All enclosures are available in surface-mounted design. Each enclosure is NEMA-compliant, ANSI 61 finished code gauge steel. Different enclosure types are available and compliant with the UL 50 standard:

NEMA 1

For indoor use to provide a degree of protection to personnel against access to hazardous parts and to provide a degree of protection against ingress of solid foreign objects (falling dirt). Optional drip hood is also available.

NEMA 2

For indoor use to provide a degree of protection to personnel against access to hazardous parts, falling dirt and harmful effects on the equipment due to the ingress of water (dripping and light splashing). NEMA 2 enclosure is provided with drip hood and door-in-door.

NEMA 3R

For either indoor or outdoor use to provide a degree of protection to personnel against access to hazardous parts, falling dirt and harmful effects on the equipment due to the ingress of water (rain, sleet and snow); and that will be undamaged by the external formation of ice and snow with no damage to the external enclosure.

NEMA 4/4X

For either indoor or outdoor use to provide a degree of protection to personnel against access to hazardous parts, falling dirt and windblown dust, and effects on the equipment due to the ingress of water (rain, sleet, snow, splashing water and hose-directed water) and with no damage from the external formation of ice on the enclosure. 4X is stainless steel and corrosion resistant.

NEMA 12

Without knockouts, for indoor use to provide a degree of protection to personnel against access to hazardous parts, falling dirt and circulating dust (lint, fibers and flyings) and to prevent harmful effects on the equipment due to the ingress of water (dripping and light splashing) and to provide a degree of protection against light splashing and consequent seepage of oil and non-corrosive coolants.

Note: For outdoor enclosures (NEMA 3R, NEMA 4/4X and NEMA 12), a padlock provision is provided on the handle of the enclosure. Padlock is not provided.



Panelboard details

Bus stack

The bus stack consists of a back pan, busbars assembled one on top of the other and an insulator to protect from live components. Some bus stack configurations are IP20¹ finger-safe, an industry-exclusive and patented feature.

It can be either bottom or top fed. Busbars can be copper or aluminum. Silver-plated copper busbars are available as heat-rated or density-rated (1000 A per square inch); aluminum busbars are available only as heat-rated. Tin-plated busbars also available for applications in harsh environments where hydrogen sulfide is present, such as water treatment facilities.

Both main lug only (MLO) and main circuit breaker (MCB) configurations are available. The main circuit breaker can be either vertically or horizontally mounted. For the main lugs option, an appropriate barrier post kit is needed.

Standard mechanical lugs are available from 250 kcmil up to 750 kcmil. Compression lugs are also offered from 1/0 to 750 kcmil.

Sub-feed (dual main) lug and feed-through lug options are also available to address instances where a panelboard requires more than one enclosure.

Six bus stack ampere ratings are available: 250 A, 400 A, 600 A, 800 A, 1000 A and 1200 A.

The bus stack dimensions are optimized to reach the highest power density and number of circuits. Four different dimensions are available: 16X, 24X, 32X and 40X.

We define X-space as the number of mounting positions available on each bus stack side. One X-space is equal to 1.385". Each circuit-breaker frame and bus-stack-mounted accessory has specific requirements for X-spaces. Each set of lug pads also requires four mounting spaces. Refer to the breaker section for more details.

ReliaGear neXT features a field-reversible bus stack that can be flipped 180 degrees to accommodate top or bottom feeds without extra parts.

¹ Per IEC Standard 60529

Possible combinations of bus stack and enclosures

Bus height	16X		24X			32X			40X		
Bus type	NN	BL	NN	BL	BF	NN	BL	BF	NN	BL	BF
Enclosure height (in.)											
60	•	•	•								
72	•	•	•	•		•					
84		•	•	•	•	•	•		•		
96				•	•	•	•	•	•	•	•

NN: clean bus, no lug pads

BL: 1 set of lug pads

BF: feedthrough, 2 sets of lug pads

Possible combinations of bus stack and plating type

Bus height	16X				24X-32X-40X			
Bus type	1P-Silver	1P-Tin	3P-Silver	3P-Tin	1P-Silver	1P-Tin	3P-Silver	3P-Tin
Bus amperage								
250 A			•	•	•	•	•	•
400 A			•	•	•	•	•	•
600 A			•	•	•	•	•	•
800 A			•	•	•	•	•	•
1000 A			•	•	•	•	•	•
1200 A			•	•	•	•	•	•

1P-Silver: Single-phase silver plating

1P-Tin: Single-phase tin plating

3P-Silver: Three-phase silver plating

3P-Tin: Three-phase tin plating



Panelboard details

Interior frame

To fit the bus stack into the enclosure, an interior frame is provided. For 30"-wide panels, the bus stack can be mounted only in the center of the enclosure. For 40"-wide panels, the bus stack must be offset, while on 45"-wide enclosures, the bus stack can be either center or offset mounted. These configurations help to achieve the highest ampacity and power density. The interior frame also allows breakers to be well-positioned and properly bolted.

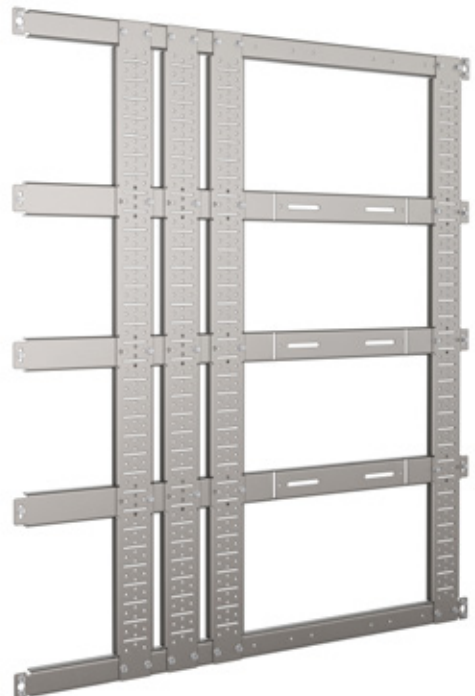
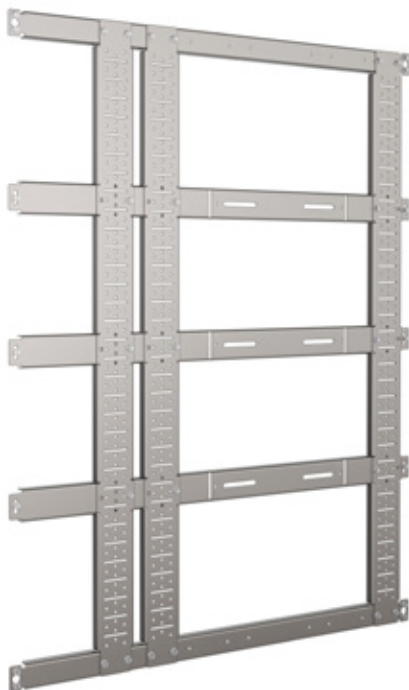

Panelboard details

Fronts, gutter doors, blanks and fillers

Top and bottom fronts, together with hinged gutter doors, complete the NEMA 1 enclosure style. Those grant independent access to either the incoming section or the branch distribution section. Vented fronts are needed when a 100% rated breaker is required.

Standard gutter doors do not prevent access to the breaker handle and trip unit settings. Options for locking doors are available to prevent access to the breakers. Locking doors are not available with horizontally mounted XT7 breakers.

With certain breaker frames, a filler is needed to cover the gap between the gutter door and the breaker load side. If the bus stack is not completely full of breakers, sheet metal blanks are needed to ensure isolation from live parts.



Panelboard details

Door-in-door option

A door-in-door option is also available with the ReliaGear neXT power panelboard.

This kit consists of two different doors, one within the other:

- The circuit breaker door, which provides access to the breaker operating levers with no risk of contact with live parts;
- The deadfront door, which gives access to the entire panel interior.

To complete the installation, a filler and a support are also needed.

The door-in-door is required with NEMA 2 enclosures.

The default option comes with an internal lock and key. Another option is for a 0.33" padlock provision. Padlock itself is not provided.



Panelboard details

Full IP20 finger-safe

In an installation, the degree of protection required for electrical equipment depends on the environmental characteristics. The degree of protection, ensured by the enclosure of equipment or by the cubicle containing the equipment, is expressed by the IP code, which indicates the level of protection against access to hazardous parts, the ingress of foreign bodies and/or the ingress of water, in compliance with IEC 60529, IEC 60947-1. Besides the IP symbol, the complete code has two figures followed (optionally) by two additional letters. For IP20-rated equipment, protection is provided against ingress of foreign bodies > 12.5 mm in diameter.

ReliaGear neXT full IP20 is compatible with the following panel types:

- Horizontally mounted main circuit breaker (MCB)
- Horizontally mounted MCB + feed-through lug
- Main lug only (MLO)
- Main lug + feed-through lug

The ReliaGear neXT full IP20 offering consists of the following finger-safe protected connections:

- **Plug-in breaker (line* side):** Protection provided by the ReliaGear neXT line side connector technology and the ReliaGear neXT finger-safe bus stack. Refer to the bus stack section for more details.
- **Plug-in breaker (load* side):** Protection provided by pre-installed service entrance/finger-safe lug barriers (not available in all breaker frames). Refer to the service entrance barrier section for more details.
- **Main lug / feed-through lug:** Protection provided by the main lug barrier kit, which covers the bus stack lug pads and mechanical lugs, if applicable. See the full IP20 main lug barrier section for more details.

* For plug-in (horizontally mounted) MCBs, the line and load sides are reversed.

Other considerations:

- Neutrals and grounds will not be barriered off (not finger-safe)
- The IP20 main lug barrier kit, horizontal mounting rail and service entrance/finger-safe lug barriers can all be ordered separately to retrofit existing panels in the field, barring restrictions

Full IP20 is not available for the following panel configurations:

- Single-phase voltage
- DC voltages: 125 V DC and 250 V DC 2-wire
- Vertical main breakers
- Dual main lugs
- Compression lugs
- Dual main compression lugs
- FB or TEY breakers (service entrance/finger-safe lug barriers are not available)

For additional information on ReliaGear neXT full IP20, please refer to [1SQ900004N0201](#).



Panelboard details

Panelboard configurations

The ReliaGear neXT panelboard is available with differently sized bus stack configurations. Once the main bus ampacity is determined, the height of the bus determines both the height of the panelboard and the maximum number of available outgoing branch Tmax XT, Record Plus® FB, TEY, and Formula A2 circuit breaker X-spaces. Different circuit-breaker frame sizes require different numbers of mounting positions on the bus stack. See page 43 for details. Main lugs and main circuit breaker options are both available up to 1200 A. The main circuit breaker can be either vertically or horizontally mounted. For vertical circuit-breaker mounting, XT5 or XT7 mounting kits are required.

All ReliaGear neXT panelboards are double sided, with branch breakers that can fit on both the left and right sides of the bus stack. The maximum ampacity of the breakers selected will determine the width of the panelboard needed. The bus stack can either be mounted in the center of the box or be offset to the right (default) or to the left. With an offset configuration, the maximum ampacity of the branch breakers mounted on the narrow and wide sides is different. This allows the panelboard to comply with the wire-bending space requirements per UL 67.

Available configurations

Panelboard width (in.)	Bus stack position inside the box	Max. branch breaker ampacity on wide side (A)	Max. branch breaker ampacity on narrow side (A)
30	Center	250 (XT4)	250 (XT4)
40	Offset	600 (XT5)	250 (XT4)
45	Center	600 (XT5)	600 (XT5)
45	Offset	1200 (XT7)	250 (XT4)

Note:

- Horizontally mounted XT5 with 750 kcmil lugs can fit only in 45" offset box
- 250 A for XT4 available on the narrow side only with 350 kcmil internal lugs (breaker digit 12 = "8")

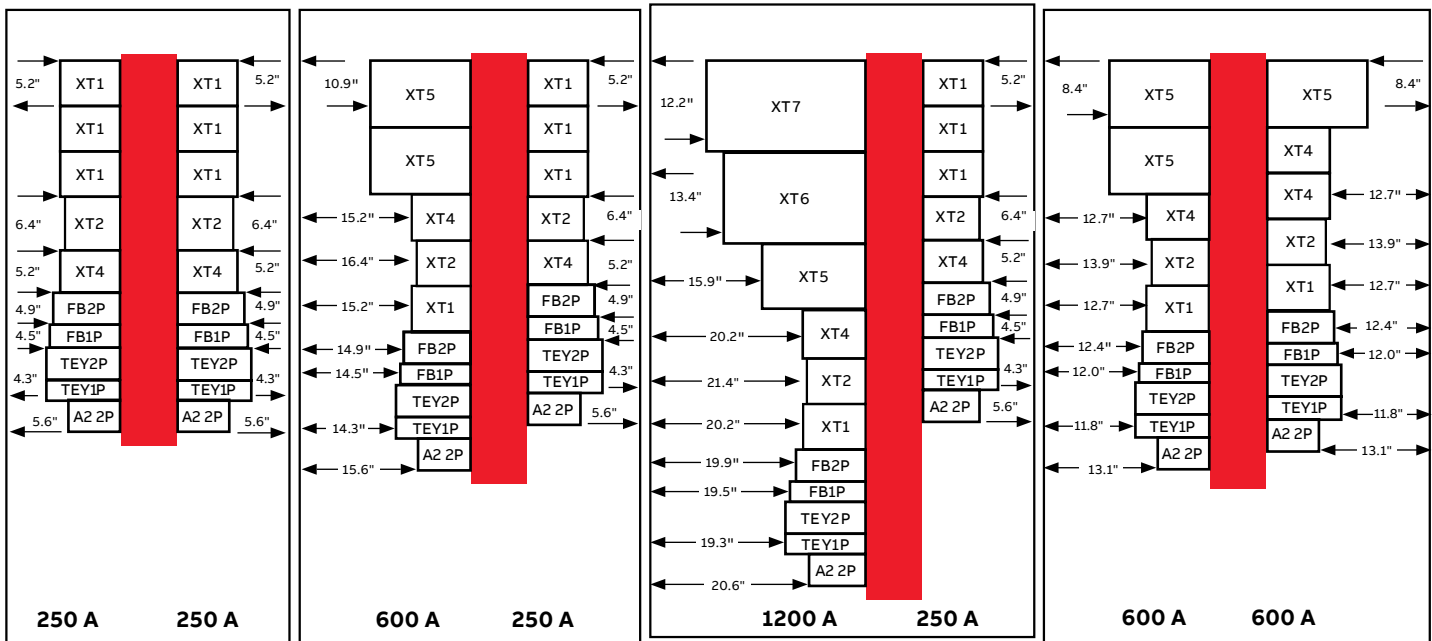

30" center box

40" offset box

45" offset box

45" center box

4 configurations

Note:

- Configurations and dimensions above are based on default lug option for each breaker frame. Allowable configurations may be limited based on wire size selected.
- For XT5 and XT6 breakers with 750 kcmil lugs, WBS shown above is reduced by 0.8" and 1.2" respectively.

Panelboard details

Assembly details

Torque values for panelboard hardware

Screw size	Location	Torque (in.-lb.)
¼-20 steel-thread forming	Fronts to enclosure (sides)	85-95
	Interior frame to enclosure	
	Neutral and ground to enclosure	
	Fillers to gutter covers	
	Vertical main mounting kit for enclosure	
	Fronts to enclosure (top/bottom)	50-58
	Branch breakers to interior frame	
	Panelboard interior to interior frame	
	Vertical main insert/filler(s) to panels	
	Blanks to interior frame	

01 The enclosure depth is 10.8" for NEMA 1 and 14.5" for all other NEMA types. Refer to the drawing at right for mounting hole locations.

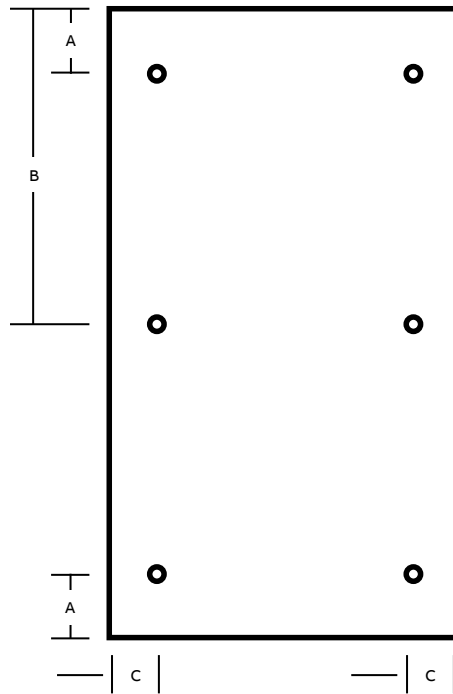

01

NEMA 1 enclosure mounting holes
Plate hole distance from edges

Height	Holes	A	B	C
60"	4	5"	-	8"
72"	4	5"	-	8"
84"	6	5"	42"	8"
96"	6	5"	48"	8"

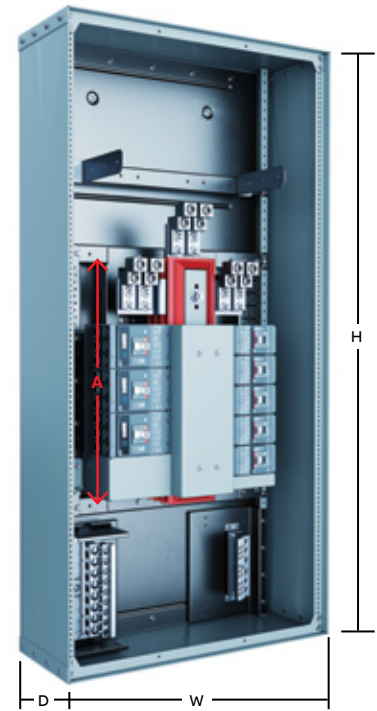

Panelboard dimensions

	60"	72"	84"	96"
H	60"	72"	84"	96"
A	16X	24X	32X	40X
W		30"	40"	45"
D				11" NEMA 1 14.5" NEMA 1 + DiD 14.5" NEMA 2/3R* 14.8" NEMA 4/4X/12*

*Depth for NEMA 3R/4/4X/12 does not include 0.9" of hanger bracket.

Refer to instruction sheet **15QC900008M0201** for conduit space and detailed enclosure dimensions. Enclosure dimensions can also be found on empower drawing. Dimensions above are general.

Panelboard details
Accessories



Neutrals

Neutral with lug sizes ranging from 1/0 to 750 kcmil (accepting both copper and aluminum wires). Neutrals are all isolated, and bonding kit is included. 200% neutrals are available.

Ground fault neutrals with ground fault CTs are also available for main breaker and feeder breakers. Main and feeder breaker ground fault protection are compatible together.

- Available in 40" and 45" wide enclosures
- Ground fault protection not available in single phase applications

Breaker frame	Ground fault on main	Ground fault on feeder
XT2		•
XT4	•	•
XT5	•	•
XT7	•	

* Maximum number of ground fault feeders is 6



Grounds

Grounding kits are available in both isolated and bonded versions. They can accommodate 10 or 47 wires, aluminum or copper.

Service entrance / finger-safe barriers

Service entrance kits can be installed on the load side lugs of the below breaker frames to make breaker IP20¹ finger-safe. Service entrance kits are available for the following breakers:

Breaker frame	Service entrance wire range
XT1	(1) No. 10–2/0 AWG
XT2	(1) No. 10–2/0 AWG
A2	(1) 1 AWG–250 kcmil (Cu) or (1) 2/0 AWG–300 kcmil (Al)
XT4	(1) 4 AWG–350 kcmil
XT4	(1) 3/0 AWG–350 kcmil
XT5	(2) 2/0 AWG–500 kcmil
XT5	(2) 500 kcmil–750 kcmil
XT6	(3) 2/0 AWG–400 kcmil
XT6	(2) 500 kcmil–750 kcmil
XT7	(4) 4/0 AWG–500 kcmil
XT7	(3) 500 kcmil–750 kcmil

¹ Per IEC standard 60529.



Panelboard details

Accessories

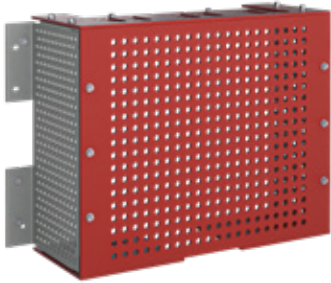

Full IP20 main lug barrier

The IP20 main lug barrier kit mounts over the lug pads of the bus stack, creating a finger-safe connection between incoming cables and lugs. It consists of a set of insulator barriers (top / bottom / front) and a pair of sheet metal support brackets. The kit ships in a flat pack, to be assembled at a customer site. It requires (1) additional horizontal mounting rail to be installed in the enclosure.

Panel main wires should be brought into the enclosure before the top and front barriers are installed. The top barrier is selected based on the number of cables. For more detailed information, please refer to:

Installation instructions — [1SQC900024M0201](#)



Surge protection devices

The SPD module is a plug-in accessory to be installed on the bus stack. This accessory can fit into panels 40" or 45" wide.

— Available in different configurations according to system voltage, impulse current and type:

System voltage	120 V AC Wye, 277 V AC Wye, 347 V AC Wye, 480 V AC Delta
Impulse current	65 kA, 80 kA, 125 kA, 150 kA, 200 kA, 300 kA
SPD type (according to NEC)	Type 1: Surge arrester Type 2: TVSS

Note: For more details please refer to [1SQC900022M0201](#).



RELT module

When activated, the RELT (reduced energy let-through) module helps to mitigate arc flash hazard, limiting the duration of fault current through the use of a user-selectable and settable secondary instantaneous pickup setting. This is a plug-in accessory to be installed on the bus stack, compatible with XT7 breakers with Ekip Touch trip units and can fit into panels 40" or 45" wide.

An additional wiring kit is needed to connect the module to the main circuit breaker, which must be equipped with an Ekip Signaling module.

Three different versions are available to cover all system voltages:

- 240 V–208/120 V
- 480 V–480/277 V
- 600 V–600/347 V



Drip hood

The drip hood prevents droplets from falling into the enclosure. A drip hood is supplied standard with NEMA 2 enclosures, and is optional for NEMA 1 enclosures.



Panelboard details

Accessories



Single-point metering unit: AMP1

The AMP1 power and energy meter provides an integrated solution for power monitoring and single-point metering. With exceptional performance, the AMP1 monitors key electrical parameters of the main power coming into the panelboard. This information can then be transmitted to a building automation system (BAS), or similar system, to analyze usage and identify potential cost-saving measures. Offering ANSI 12.20 0.5% accuracy, the AMP1 is revenue-grade and features:

- Voltage, amperage, power and energy monitoring
- Backlit LCD display
- Data logging option to ensure data is still preserved locally
- Communication via Modbus RTU or BACnet – Versatile and widely used protocols
- User-enabled password protection
- UL 67 approval

The AMP1 module is a plug-in accessory to be installed on the bus stack. This accessory can fit into panels 40" or 45" wide.

A set of current transformers must be selected according to the ampacity needed for metering, together with a mounting kit for proper installation.

Upgraded single-point metering unit: RGM40

The RGM40 meter is a compact energy and power quality meter that provides multifunction measurement of all electrical parameters and makes the data available in multiple formats via display and communication systems. Offering ANSI C12.20 0.2% accuracy, the RGM40 is revenue-grade and features:

- Multifunction measurement including voltage, amperage, power, frequency, energy, etc.
- LED display
- Data logging (V2 and V6 versions)
- Extensive memory for storing load profiles, system events and limits/alarms
- Communication via Modbus RTU, TCP or BACnet
- Power quality features include waveform recording at 512 samples/cycle and harmonic analysis
- System events log and passwords for security
- UL 67 approval

The RGM40 module is a plug-in accessory to be installed on the bus stack. This accessory can fit into panels 40" or 45" wide.

A set of current transformers must be selected according to the ampacity needed for metering, together with a mounting kit for proper installation.

For more detailed information on the RGM40 single-point metering unit, please refer to:

Brochure — **1SQ173001B0201**

Quick start guide — **1SQ173001M0201**

User manual — **1SQ173002M0201**

Panelboard details

Accessories

Revenue grade submetering unit

The ReliaGear neXT submetering plug-in module combines the meters, current transformers, communications and overload protection into a single module that mounts inside a UL Listed factory-assembled panel. This solution can reliably allocate energy usage for commercial, industrial, institutional and residential applications. Accurate energy usage allocation allows facility managers to sub-bill tenants and manage, understand and reduce operational costs while also incentivizing tenants to conserve energy and lower their monthly bill.

Offering ANSI 12.20 0.5% accuracy, the submetering module is revenue-grade and features:

- Voltage, amperage, power and energy monitoring
- Local LCD display
- Data Logging
- Communications via Modbus RTU - Versatile and widely used protocol
- Modular units that can serve up to 48 circuits to be metered
- UL 2808 XOBA rated current transformers
- California weights and measures certified certificate number: 5876(b)-22

The submetering module is a plug-in accessory to be installed on the bus stack. This accessory can fit into 40" or 45" wide.

Refer to submetering brochure [1SQ900005B0201](#) for more detailed information on the offering.

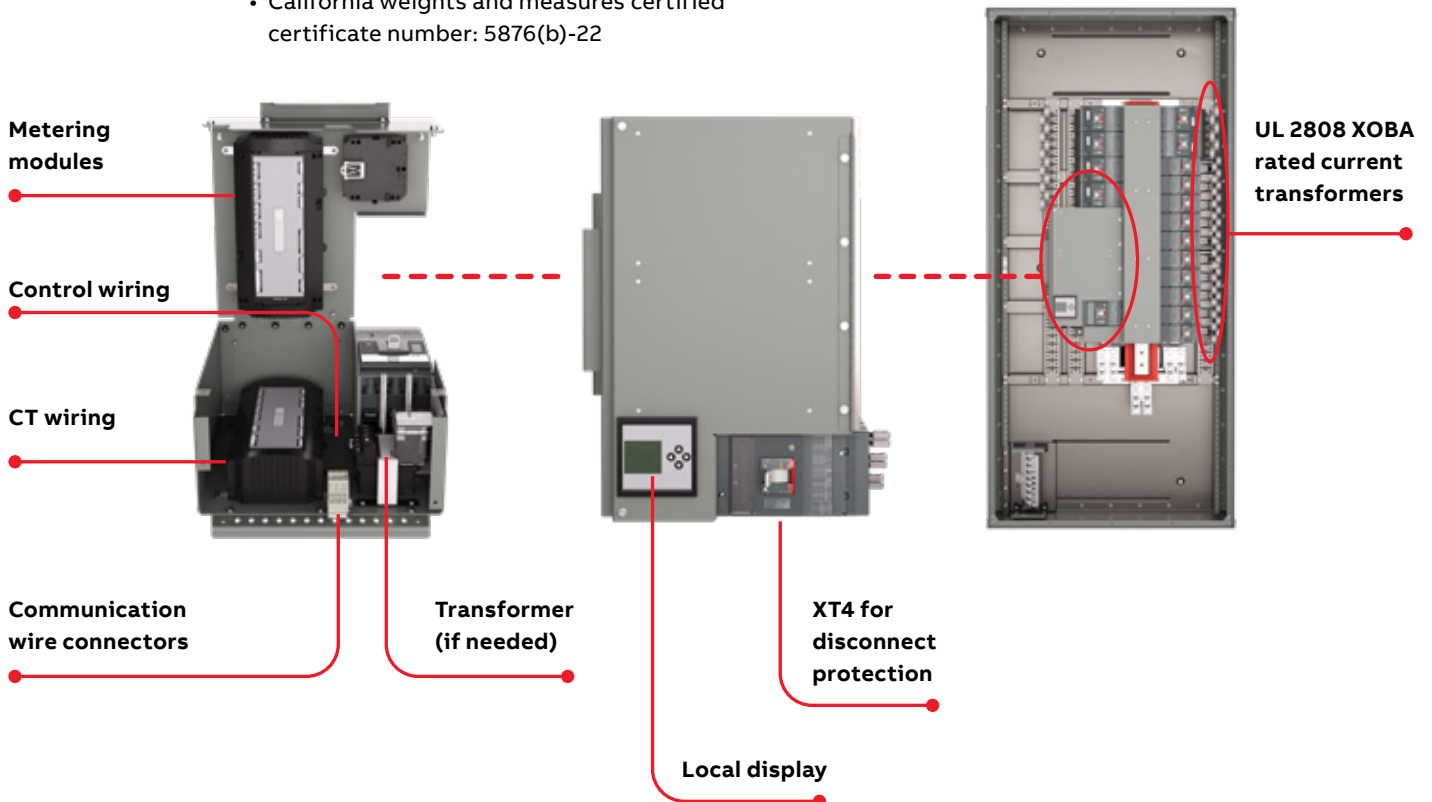

—

03

Molded case circuit breakers

Molded case circuit breakers

Molded case circuit breakers	
Tmax XT range — AC ratings	34–35
Tmax XT range — DC ratings	36–37
Tmax XT range — 100% rated breakers	38
Tmax XT range — trip units	39–44
Record Plus FB, TEY, and Formula A2 — AC ratings	45
Record Plus FB, TEY, and Formula A2 — DC ratings	46
Mounting space requirements	47
Line-side connectors and lugs	48
Breaker accessories	49–50
Installation manuals	51
Connectivity	52

Tmax[®] XT range

ReliaGear molded case circuit breakers for alternating current (AC) distribution

The SACE[®] Tmax XT range offers higher performance, better protection and more precise metering than equivalent units and can handle from 15 A up to 1200 A.

Combined with precise electronic trip units in small frames, the new range delivers significant time savings and enhances installation quality. Reliability is further increased, and speed of installation reduced, thanks to Bluetooth and Ekip connectivity for mobile devices. Tmax XT circuit breakers and their accessories are constructed in compliance with UL 489 and CSA C22.2 standards.

The molded case circuit breakers for ReliaGear neXT power panelboards can also be used in ReliaGear SB switchboards. The same mounting hardware, fillers, blanks and rails are also applicable for ReliaGear SB.

Note: Tmax XT MCCBs for ReliaGear neXT power panelboards and ReliaGear SB switchboards come with filler plates when ordered separately, except XT1 where the XT1 group-mount rail kits need to be ordered separately. Refer to fillers and blanks in the numbering system chapter.



Molded case circuit breakers (MCCB)

				XT1		
Frame size		[A]		125		
Poles		[No.]		3		
Rated voltage	(AC) 50–60 Hz	[V]		480 V Δ ⁽²⁾		
Versions				Fixed		
Interrupting ratings				N	S	H
	240 V (AC)	[kA]		50	65	100
	480 V (AC)	[kA]		25	35	65
	600Y/347 V (AC)	[kA]		18	22	25
	600 V (AC)	[kA]		–	–	–
Mechanical life		[No. operations]		25000		
		[No. hourly operations]		240		
Dimensions – fixed (width x depth x height)	3 poles	[mm]/[in]		[77 x 184 x 265] / [3.0 x 7.2 x 10.4]		
Weight	Fixed 3 poles	[kg]/[lb]		[1.9] / [4.2]		

Trip units for power distribution

TMF

TMA

Ekip DIP

Ekip Touch

(1) Current-limiting circuit breaker in 480 V AC and 600 V AC

(2) 600Y/347



XT2						XT4						XT5						XT6						XT7					
125						250						400-600						800						800-1000-1200					
3						3						3						3						3					
600						600						600						600						600					
Fixed						Fixed						Fixed						Fixed						Fixed					
N	S	H ⁽¹⁾	L ⁽¹⁾	V ⁽¹⁾	X	N	S	H ⁽¹⁾	L ⁽¹⁾	V ⁽¹⁾	X	N	S	H ⁽¹⁾	L ⁽¹⁾	V ⁽¹⁾	X	N	S	H	S	H	L	N	S	H	S	H	L
65	100	150	200	200	200	65	100	150	200	200	200	65	100	150	200	200	200	65	100	150	200	200	200	65	100	200	65	100	200
25	35	65	100	150	200	25	35	65	100	150	200	35	50	65	100	150	200	35	50	65	50	65	100	35	50	65	50	65	100
-	-	-	-	-	-	-	-	-	-	-	-	-	-	-	-	-	-	-	-	-	-	-	-	-	-	-	-	-	-
18	22	25	35	42	42	18	22	25	50	65	100	18	25	35	65	100	100	20	25	35	25	50	65	20	25	35	25	50	65
25000						25000						20000						20000						10000					
240						240						240						240						240					
[105 x 198 x 249] / [4.1 x 7.8 x 9.8]						[105 x 198 x 249] / [4.2 x 7.8 x 9.8]						[141 x 206 x 387] / [5.6 x 8.1 x 15.2]						[210 x 211 x 488] / [8.3 x 8.3 x 19.2]						[211 x 277 x 488] / [8.3 x 10.9 x 19.2]					
[2.8] / [6.1]						[3.2] / [7.0]						[7.0] / [15.4]						[12.0] / [26.5]						[17.2] / [37.9]					
•						•																							
•												•						•						•					
•						•						•						•						•					
•						•						•						•						•					

Tmax[®] XT range

ReliaGear molded case circuit breakers for direct current (DC) distribution

The SACE[®] Tmax XT range in ReliaGear neXT power panels are qualified for DC ratings for 125 V DC 2-wire and 250 V DC 2-wire applications with breakers offered from 15 A up to 800 A.

DC applications in ReliaGear neXT will take advantage of the single-phase bus stacks using phase A and C connections.

Tmax XT in ReliaGear neXT for DC applications feature 2-pole line-side connectors, and trip units are limited to thermal magnetic only.



Molded case circuit breakers (MCCB)

		XT1		
Frame size	[A]	125		
Poles	[No.]	2		
Rated voltage (DC)	[V]	250		
Versions		Fixed		
Interrupting ratings		N	S	H
	250 V (DC) 2 poles in series	[kA]	35	42
Mechanical life	[No. operations]	25000		
	[No. hourly operations]	240		
Dimensions — fixed (width x depth x height)	3 poles [mm]/[in]	[77 x 184 x 265] / [3.0 x 7.2 x 10.4]		
Weight	3 poles [kg]/[lb]	[1.9] / [4.2]		
Trip units for power distribution				
TMF		●		
TMA				



XT2		XT4		XT5		XT6		
125		250		400-600		800		
2		2		2		2		
250		250		250		250		
Fixed		Fixed		Fixed		Fixed		
N	S	N	S	H	N	S	N	S
35	50	35	42	50	35	50	35	50
25000		25000		20000		20000		
240		240		240		240		
[105 x 198 x 249] / [4.1 x 7.8 x 9.8]		[105 x 198 x 249] / [4.2 x 7.8 x 9.8]		[141 x 206 x 387] / [5.6 x 8.1 x 15.2]		[210 x 211 x 488] / [8.3 x 8.3 x 19.2]		
[2.8] / [6.1]		[3.2] / [7.0]		[7.0] / [15.4]		[12.0] / [26.5]		
●		●		●		●		
●		●		●		●		

Tmax XT range

100% rated breakers

All Tmax XT circuit breakers are available both as standard versions and as 100% rated versions. Because of the additional heat generated at 100% of continuous current rating, the use of specific 90 °C rated wires sized per 75 °C ampacity may be required.

Frame	Max. ampacity (A)	Wires
XT4	200	75 °C
XT5	400	75 °C
XT7	800	75 °C
XT7	1000/1200	90 °C



Tmax XT range

Trip units

SACE Tmax XT trip units represent a new benchmark for molded case circuit breakers, being able to satisfy any performance requirement.

The Tmax XT trip units are designed to be used in a wide range of applications. These complete, flexible protection trip units can be adapted to the actual level of protection required, independently of the complexity of the system.

The range is available for three levels of performance to meet any requirement, from simple to advanced applications:

- TM thermal-magnetic trip unit
- Ekip DIP electronic trip unit
- Ekip Touch/Hi-Touch electronic trip units

For the single-phase offering, the following trip units are available:

- XT1, XT2, XT4, XT5, XT6:
 - TM thermal-magnetic trip unit
- XT7:
 - Ekip DIP electronic trip unit
 - Ekip Touch/Hi-Touch electronic trip units

For the DC offering, the following trip units are available:

- XT1, XT2, XT4, XT5, XT6:
 - TM thermal-magnetic trip unit

Tmax XT range

Thermal-magnetic trip unit

The thermal-magnetic trip unit is an easy solution for protection against overloads and short circuits. Overload protection is ensured by the ABB thermal device, based on a temperature-dependent bimetal heated by current. Protection against short-circuit is realized with a magnetic device.

- Key:
1. Current threshold for short-circuit protection.
 2. Rotary switch for short-circuit protection.
 3. Current threshold for overload protection.
 4. Rotary switch for overload threshold setting.



Rotary switch

Depending on the version, it is possible to set the desired thresholds for protection by turning the front rotary switch.

Tmax XT range

Thermal-magnetic trip unit

Field of application	Trip unit	L – overload protection			I – short-circuit protection	
		Current threshold	Trip time	Current threshold	Trip time	
Power distribution protection	TMF	Fixed	Fixed	Fixed	Fixed instantaneous	
	TMA	Adjustable	Fixed	Adjustable	Fixed instantaneous	

—
TMF

In [A]	15	20	25	30	35	40	45	50	60	70	80	90	100	110	125	150	175	200	225	250	
XT1	•	•	•	•	•	•	•	•	•	•	•	•	•	•	•						
XT2	•	•	•	•	•	•		•	•	•											
XT4			•	•	•	•		•	•	•	•	•	•	•	•	•	•	•	•	•	•

—
TMA

In [A]	80	90	100	110	125	150	175	200	225	250	300	400	500	600	800
XT2	•	•	•	•	•										
XT5											•	•	•	•	
XT6														•	•

Tmax XT range

Ekip DIP

The first level of electronic trip units, Ekip DIP trip units, are based on microprocessor technologies and guarantee high reliability, protection adjustability and coordination.

They provide protection against overloads, selective short circuits, short circuits and ground faults. The power required for their operation is provided directly from the current sensors.

- Key:
1. DIP switches for overload-protection setting.
 2. DIP switches for short-circuit and time-delayed short-circuit.
 3. Slot for lead seal.
 4. Test connector.
 5. Power-on LED.

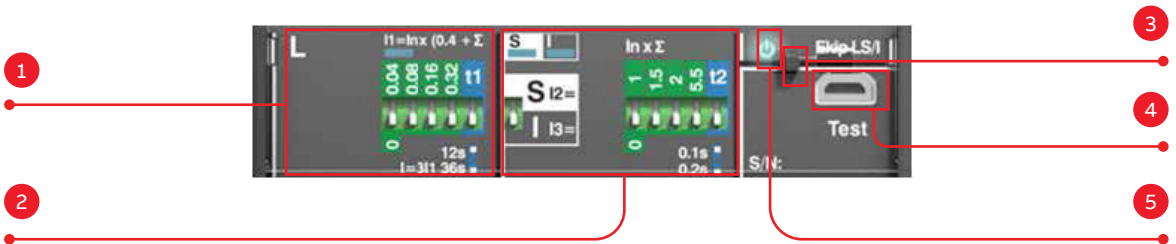

DIP switches

The DIP switches on the front of the trip unit allow manual settings when the trip unit is off.

LEDs

The LEDs on the front indicate the status of the release (on/off) and provide information about the protection tripped when the Ekip TT accessory is connected.

Front connector

The connector on the front of the unit allows the connection of:

- Ekip TT for trip testing, LED-test and signaling of the most recent trip.
- Ekip T&P for connection to a laptop with the Ekip Connect program (thus measurement reading, as well as trip and protection function tests, are made available to the user).

Thermal memory

All the Ekip DIP trip units include a thermal memory function. The trip unit records the trips that have occurred in the last few minutes. Since the trip causes overheating, to protect the cables and let them cool down, the trip unit imposes a shorter delay-tripping time in case of a fault. Thus, the system is protected against damage due to cumulative overheating. This can be disabled if needed by using the Ekip T&P.

Characteristics of electronic Ekip DIP trip units

Operating temperature	-25 °C to +70 °C
Relative humidity	98%
Self-supplied	0.2xIn (single phase)*
Auxiliary supply (where applicable)	24 V DC ± 20%
Operating frequency	45 to 66 Hz
Electromagnetic compatibility	IEC 60947-2 Annex F

*For 10 A: 0.4 in

Tmax XT range

Ekip DIP

Field of application	Trip unit	L – overload protection			S – selective short-circuit protection			I – short-circuit protection	
		Current threshold	Trip time	Current threshold	Trip time	Current threshold	Trip time		
Power distribution protection	Ekip DIP	LSI	Adjustable	Adjustable	Adjustable	Adjustable	Adjustable	Fixed	

In [A]	10	25	40	60	100	125	150	250	400	600	800	1000	1200
XT2		•		•		•							
XT4			•	•	•		•	•					
XT5								•	•	•			
XT6											•		
XT7										•	•	•	•

Breaker frame	Sensor	Minimum trip amps
XT2–125 A	25 A	10 A
	60 A	30 A
	125 A	70 A
XT4–250 A	40 A	15 A
	60 A	25 A
	100 A	40 A
	150 A	60 A
	250 A	100 A
XT5–400 A	250 A	100 A
	400 A	175 A
XT5–600 A	600 A	250 A
XT6–800 A	800 A	350 A
XT7–800 A	600 A	250 A
	800 A	350 A
XT7–1000 A	1000 A	400 A
XT7–1200 A	1200 A	500 A

Tmax XT range

Ekip Touch/Hi-Touch

Ekip Touch/Hi-Touch trip units provide a wide series of protections and high accuracy measurements of all electrical parameters. They are intended to integrate perfectly with most common automation and supervision systems.

Key:

1. Power-on LED; pre-alarm LED; alarm LED.
2. Test and programming connector.
3. Display.
4. Home pushbutton to return to homepage.
5. Pushbutton for testing and tripping information.



Communication and connectivity

The Ekip Touch/Hi-Touch trip units integrate perfectly into most common automation and energy management systems to improve productivity and energy consumption and for remote control. The circuit breakers can be equipped with communication modules for Modbus, Profibus and DeviceNet™ protocols, as well as Modbus TCP, Profinet and EtherNet/IP™. The modules can be easily installed even at a later date.

Furthermore, the IEC 61850 communication module enables connection to automation systems widely used in medium-voltage power distribution to create intelligent networks (smart grids). In addition, with an easy connection thanks to the Ekip Com hub module, the circuit breakers allow the system to be monitored via ABB Ability EDCS.

The integrated display makes interaction with the Ekip Touch/Hi-Touch an easy and intuitive experience for the user, and the embedded Bluetooth functionality allows fast interaction via EPiC (electrification products intuitive configurator), the new mobile application to configure and check the status of ABB low-voltage circuit breakers.

Tmax XT range

Ekip Touch/Hi-Touch

Trip unit	Current measurement and protection	Voltage, power, energy measurements	Voltage, power, energy protections	Embedded functions*
Ekip Touch LSI	•	○	○	○
Ekip Touch LSI	•	○	○	○
Ekip Touch Measuring LSI	•	•	○	○
Ekip Touch Measuring LSI	•	•	○	○
Ekip Hi-Touch LSI	•	•	•	•
Ekip Hi-Touch LSI	•	•	•	•

• Default available

○ Additional features

* Please refer to the Tmax XT catalog 15XU210248C0201 for more details.

LSIG trip units not available for single phase applications

In [A]	40	60	100	125	150	250	400	600	800	1000	1200
XT2	•		•	•							
XT4			•		•	•					
XT5						•	•	•			
XT7								•	•	•	•

Breaker frame	Sensor	Minimum trip amps
XT2-125 A	40 A	15 A
	100 A	45 A
	125 A	110 A
XT4-250 A	100 A	40 A
	150 A	60 A
	250 A	100 A
XT5-400 A	250 A	100 A
	400 A	175 A
XT5-600 A	600 A	250 A
XT7-800 A	600 A	250 A
	800 A	350 A
XT7-1000 A	1000 A	400 A
XT7-1200 A	1200 A	500 A

Record Plus FB, TEY and Formula A2

ReliaGear molded case circuit breakers for alternating current (AC) distribution

Record Plus FB, TEY and Formula A2 circuit breakers complete the breakers offering for the ReliaGear neXT panelboard.

The Record Plus FB line features true one- and two-pole construction, has a double-break contact system for fast response and current limitation to help with arc flash and coordination. This non-adjustable thermal-magnetic circuit breaker up to 100 A offers four interrupt tiers — through 100 kA at 480 V AC and 35 kA at 600/347 V AC.

TEY also offers true one-pole construction up to 70 A and two-pole construction up to 125 A. This line offers non-adjustable thermal-magnetic trip units with three interrupt tiers — through 100 kA at 240 V and 65 kA at 480/277 V AC.

The Formula A2 line features true two-pole breaker construction from 125A to 250A. This line offers fixed (non-adjustable) thermal-magnetic trip units with two interrupt tiers - 10 kA and 25 kA at 240 V.

Note: FB, TEY and A2 MCCBs for ReliaGear neXT power panelboards and ReliaGear SB switchboards come with filler plates when ordered separately.

Record Plus FB

Poles	1, 2
Amperes	15, 20, 25, 30, 35, 40, 45, 50, 60, 70, 80, 90, 100
Trip unit	Fixed thermal-magnetic

Interrupting ratings

Ampere rating	Type	Poles	UL listed interrupting rating rms symmetrical kA AC voltage				
			240 V	277 V	347 V	480 V	600 V
15-100	FBV	1	35	35	22	-	-
		2	65	-	-	35	22
	FBN	1	65	65	25	-	-
		2	150	-	-	65	25
	FBH	1	100	100	35	-	-
		2	200	-	-	100	35
	FBL	1	100	150	42	-	-
		2	200	-	-	150	42

Formula A2

Ampere rating	Type	Poles	UL listed interrupting rating rms symmetrical kA AC voltage	
			240 V	480/277 V
125-250	A2A	2	10	25
	A2N	2	25	25

TEY

Poles	1, 2
Amperes	15, 20, 25, 30, 35, 40, 45, 50, 60, 70, 80, 90, 100, 110, 125
Trip unit	Fixed thermal-magnetic

Interrupting ratings

Ampere rating	Type	Poles	UL listed interrupting rating rms symmetrical kA AC voltage	
			120/240 V	480/277 V
15-70 (1-pole)	TEYD	1-2	65	25
15-125 (2-pole)	TEYH	1-2	65	35
	TEYL	1-2	100	65

- 01 1-pole FB
- 02 2-pole FB
- 03 1-pole TEY
- 04 2-pole TEY
- 05 Formula A2



Record Plus FB, TEY and Formula A2

ReliaGear molded case circuit breakers for direct current (DC) distribution

Record Plus FB, TEY and Formula A2 circuit breakers also offer DC ratings within ReliaGear neXT panelboards.

DC ratings are available in ReliaGear neXT for the Record Plus FB and Formula A2 line for the 2-pole construction only.

TEY offers both 1- and 2-pole.

Record Plus FB

Poles	1, 2
Amperes	15, 20, 25, 30, 35, 40, 45, 50, 60, 70, 80, 90, 100
Trip unit	Fixed thermal-magnetic

Interrupting ratings

Ampere rating	Type	Poles	UL listed interrupting rating kA DC voltage	
			125 V DC, 2-wire	250 V DC, 2-wire
15-100	FBV	2	25	25
	FBN	2	30	30
	FBH	2	42	42
	FBL	2	50	50

TEY

Poles	1, 2
Amperes	15, 20, 25, 30, 35, 40, 45, 50, 60, 70, 80, 90, 100, 110, 125
Trip unit	Fixed thermal-magnetic

Interrupting ratings

Ampere rating	Type	Poles	UL listed interrupting rating kA DC voltage	
			125 V DC, 2-wire	250 V DC, 2-wire
15-70 (1-pole)	TEYL	1	14	-
15-125 (2-pole)	TEYL	2	42	18

Formula A2

Ampere rating	Type	Poles	UL listed interrupting rating kA DC voltage	
			125 V DC, 2-wire	250 V DC, 2-wire
125-250	A2A	2	10	10
	A2N	2	25	25

01 1-pole FB

02 2-pole FB

03 1-pole TEY

04 2-pole TEY

05 Formula A2



Mounting space requirements

For molded case circuit breakers

Each circuit breaker frame has specific requirements for the number of mounting positions (X-spaces). Thanks to the optimized dimensions of the XT1, the mounting positions required are lower when two or five breakers are mounted close to one another.

SPD, metering and RELT also require X-space, since they are plug-in modules. Refer to the table below. In main lugs configuration, each set of lug pads occupies 4 X-spaces. A set of lug pads is needed also with a vertical main breaker.

Frame	Max. ampacity (A)	Poles	X-spaces
Single XT1	125	3	3
Two XT1	125	3	5
Five XT1	125	3	11
XT2	125	3	3
XT4	250	3	3
XT5	600	3	4
XT6	800	3	6
XT7	1200	3	6
FB	100	1	1
FB	100	2	2
TEY	70	1	1
TEY	125	2	2
A2	250	2	2
SPD	-	-	10
RELT	-	-	3
Main metering	-	-	4
Submetering	-	-	9-14

- 01 Single XT1
- 02 Two XT1
16% space saving
- 03 Five XT1
26% space saving

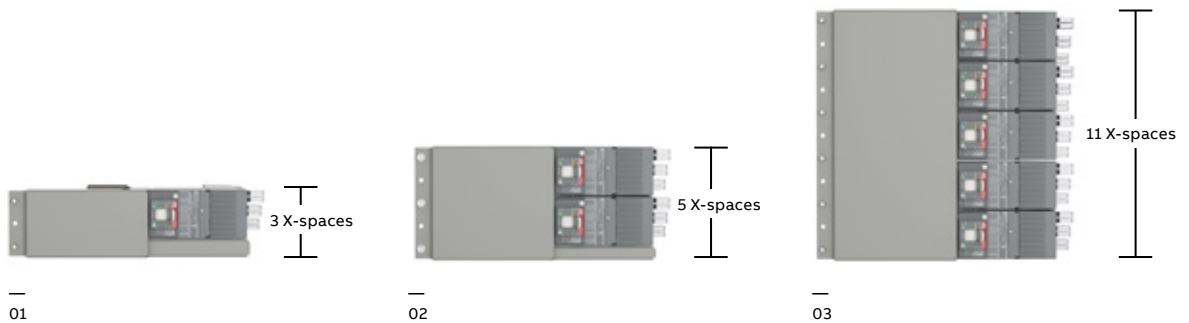

Note: Installation of Tmax XT1 circuit breakers requires a rail for ReliaGear neXT power panelboards and ReliaGear SB switchboards. Refer to Fillers and blanks in the numbering system chapter.

For replacement breakers or additional breakers being added to the panel, use the below table to select the required fillers and blanks to fill in leftover X space.

Space to be filled	30" center	40" offset left	40" offset right	45" center	45" offset left	45" offset right
1X	SR01BB	SR01BF	SR01BB	SR01BF	SR01BF	SR01BB
2X	SR02BB	SR02BF	SR02BB	SR02BF	SR02BF	SR02BB
3X	SR03BB	SR03BF	SR03BB	SR03BF	SR03BF	SR03BB

Line-side connectors and lugs

For molded case circuit breakers

Line-side connectors

Each breaker horizontally mounted on the bus stack is provided with a line-side connector (LSC) and a mounting bracket. The LSC is designed to ensure an easy and accurate connection between the breakers and the conductive busbars. A patented clip design with a loaded spring ensures full contact in any circumstance. Each breaker frame has a specific LSC with the right number of clips to ensure the highest performance.

Breaker lugs offering

All ReliaGear neXT breakers are provided with a set of lugs on the load side. All lugs accept either copper or aluminum wires.

Breaker lugs

Frame	Ampacity (A)	Wire size (AWG or kcmil) Cu or Al	Number of cables per lug	Installation
XT1	125	#10-2/0	1	Horizontal
XT2	25	#14-1/0 (Cu)	1	Horizontal
XT2	125	#10-2/0	1	Horizontal
XT4	25-70	#14-1/0	1	Horizontal
XT4	80-225	#4-300	1	Horizontal
XT4	250	3/0-350	1	Horizontal
XT5	600	2/0-500	2	Horizontal/vertical
XT5	600	500-750*	2	Horizontal/vertical
XT6	800	500-750	2	Horizontal
XT6	800	2/0-400	3	Horizontal
XT7	1200	4/0-500	4	Horizontal/vertical
XT7	1200	500-750	2**/3	Horizontal***/vertical
FB/TEY	15-20	#14-#10	1	Horizontal
FB/TEY	25-60	#10-#4	1	Horizontal
FB	70-100	#1-1/0	1	Horizontal
TEY	70-125	#4-2/0	1	Horizontal
A2	125-250	#1-250, 2/0-300	1	Horizontal
A2	250	350 (Al)	1	Horizontal

* XT5 with 750 kcmil lugs must go in 45° offset

** For horizontal installations at or below 800 A, lug offering is (3) 500-600 kcmil OR (2) 500-750 kcmil due to WBS limitation

*** For horizontal installations above 800 A, lug offering is (3) 500-600 kcmil due to WBS limitation

Accessories

For molded case circuit breakers

Internal accessories

Common internal accessories (shunt trips, undervoltage releases, auxiliary switches, etc.) are available in common voltage ratings and are UL listed for field assembly.

Auxiliary contacts — AUX

The SACE Tmax XT, Record Plus FB, TEY and Formula A2 circuit breakers can be equipped with auxiliary contacts that signal the status of the breaker and can be routed outside the circuit breaker itself. Options are one or two AUX on XT1, XT2, XT4, XT5 and XT6, four AUX on XT7, one AUX on 2-pole FB, TEY and two AUX on A2. The following information is available:

Open/closed (Q): indication of the status of the circuit-breaker power contacts

Trip (SY): signals that the circuit breaker is opening due to the intervention of the trip unit, or to the opening of undervoltage/shunt opening releases, or to the use of the test button

Shunt opening release — SOR/YO

This allows the circuit breaker to open by means of a non-permanent electrical control. Release operation is guaranteed for voltage between 70% and 110% of the rated power supply voltage (Un), in both alternating and direct current. The SOR is equipped with a built-in limit contact to shut off the power supply in the open position with the trip unit tripped.

A remote-controlled emergency opening command can be generated by connecting an opening button to the SOR.

Frame	Voltage		
XT1–XT2–XT4–XT5–XT6	24–30 V AC/DC	110–127 V AC/ 110–125 V DC	220–240 V AC/ 220–250 V DC
XT7	24 V AC/DC	110–120 V AC	220–240 V AC
FB (2-pole only)	24 V AC/DC	110–130 V AC 110–125 V DC	220–240 V AC/ 250 V DC
TEY (2-pole only)	24 V AC/DC	120 V AC	240 V AC
A2		110–127 V AC/ 110–125 V DC	

Undervoltage release — UVR/YU

This allows the circuit breaker to open when the release is subject either to a power failure or a voltage drop. As prescribed in the standards, opening is guaranteed when the voltage is between 70% to 35% Un. After tripping, the circuit breaker can be closed again if the voltage exceeds 85% of Un.

When the undervoltage release is not energized, neither the circuit breaker nor the main contacts can be closed. A remote-controlled emergency opening command can be generated by connecting an opening button to the UVR.

Frame	Voltage		
XT1–XT2–XT4–XT5–XT6	24–30 V AC/DC	110–127 V AC/ 110–125 V DC	220–240 V AC/ 220–250 V DC
XT7	24 V AC/DC	110–120 V AC	220–240 V AC
FB (2-pole only)	24 V AC/DC	110–130 V AC/ 110–125 V DC	220–240 V AC/ 250 V DC

Padlocks and key locks

Padlocks or key locks prevent the circuit breaker from being closed and/or opened. Maximum number of padlocks (PLL) and maximum stem dimensions are the following:

Frame	Padlocks*	Stem min.–max.
XT1–XT2–XT4	3	Ø 0.24–0.275" / Ø 6–7 mm
XT5–XT7	3	Ø 0.24–0.315" / Ø 6–8 mm
XT6	3	Ø 0.2–0.31" / Ø 5–8 mm
FB / TEY	1	Ø 0.25" / Ø 6.35 mm
A2	3	Ø 0.24–0.275" / Ø 6–7 mm

*Padlocks are not included in the kits.

Multiple models of keylock provisions are offered: Kirk KCAM00010 / KCAM00010S (XT5–XT7), Ronis 1228 (XT1–XT2–XT4–XT5–XT7) and Castell (XT7). Kirk and Castell locks are at customer expense and not provided in the kit. Two options are available for Ronis: same keys (type A) and different keys. This allows the customer to create interlocking logics.

Internal modules

Available with several different communication protocols, the Ekip Com internal module is installed directly inside the circuit breaker. It allows the circuit breaker to be integrated in a communication network for supervision and control. Ekip Com internal modules can be used for XT2, XT4 and XT5. They can be connected to the trip unit when Ekip Touch is used. Ekip Com modules require 24 V isolated power supply to power communications. Protocols supported include:

- Modbus RTU
- Modbus TCP/IP
- Profinet
- EtherNet/IP
- IEC 61850

Accessories

For molded case circuit breakers

Cartridge modules

Cartridge Ekip Com modules, along with the internal modules, allow integration in any communication network. They can be used only on the XT7 circuit breaker equipped with an Ekip Touch/Hi-Touch trip unit, mounted directly on the terminal box. Ekip Com modules require 24 V isolated power supply to power communications. Several modules can be used simultaneously, enabling systems with different protocols. Modbus RTU, Profibus-DP and DeviceNet modules contain a terminating resistor and two dip switches for optional activation to terminate the serial network or bus. The Profibus-DP module also contains a polarization resistor and two DIP switches for its activation.

- Modbus RTU
- Modbus TCP/IP
- Profinet
- Profibus
- Ethernet/IP
- DeviceNet
- IEC 61850

Ekip Com hub

The Ekip Com hub is the new communication module for cloud connectivity. A circuit breaker equipped with the Ekip Com hub can establish a connection with the ABB Ability Electrical Distribution Control System (EDCS) for the low-voltage power distribution panel. This dedicated module is available for the XT7 breaker even when other modules are present. For further information on ABB Ability EDCS, please see page 48.

Signaling modules

The Ekip 2K signaling cartridge modules, available for XT7, supply two input and two output contacts for control and remote signaling of alarms and circuit breaker trips.

The Ekip 1K signaling module, available for the XT5, supplies one input contact and one output contact for control and remote signaling. It is installed inside the circuit breaker in the housing provided on the left down side of the circuit breaker and can be used when an Ekip Touch/Hi-Touch trip unit is present.

Ekip signaling modules can be programmed from the trip unit display or via the Ekip Connect software and app. When using Ekip Connect, combinations of events can be freely configured.

Ekip power supply

The Ekip power supply module supplies all Ekip trip units and modules present on the XT7 with several auxiliary power sources (in AC or DC). The cartridge module permits the installation of other advanced modules. It can be field installed at any time. Two versions are available according to the control voltage:

- Ekip supply 110–240 V AC/DC
- Ekip supply 24–48 V DC

This module is always needed with any Ekip Com module or the signaling 2K module.

Accessories

Installation manuals

Additional technical information, instructions and installation manuals can be found in the following documents:

—
Installation manuals

Power panelboard	
1SQC900003M0201	Low-voltage power panel installation manual – Bulk pack
1SQC900004M0201	Low-voltage power panel installation manual – Assembled interior
1SQC900014M0201	Low-voltage power panel installation manual — Merchandise Superbox

Accessories	
1SQC900001M0201	AMP1 main circuit breaker meter
1SQC900002M0201	Door-in-door front
1SQC900005M0201	RELT unit
1SQC900006M0201	SPD unit
1SQC900007M0201	Solid neutral and ground fault neutral
1SQC900008M0201	Enclosures (NEMA 1, 3R, 4/4X, 12)
1SQC900009M0201	Dual main lug
1SQC900010M0201	Service entrance kit
1SQC900013M0201	Drip hood installation
1SQC900015M0201	Replacement part kits
1SQC900016M0201	Submetering
1SQC900017M0201	Lifting bar instructions
1SQC900020M0201	Neutral types and lug termination details
1SQC900021M0201	RGM40 main meter
1SQC900024M0201	IP20 main lug barrier

Connectivity

Scalable solution for energy and asset management

ABB Ability® Electrical Distribution Control System is the innovative cloud-computing platform designed to monitor, optimize and control the electrical system.

Part of the ABB Ability offering, ABB Ability Electrical Distribution Control System is built on a state-of-the-art cloud architecture for data collection, processing and storage. This cloud architecture has been developed together with Microsoft in order to enhance performance and guarantee the highest reliability and security. Through an intuitive web app interface, ABB Ability Electrical Distribution Control System assists anytime and anywhere via smartphone, tablet or personal computer so the user can:

- **Monitor**
Discover plant performance, supervise the electrical system and allocate costs to improve productivity and efficiency.
- **Optimize**
Schedule and analyze automatic reports, improve the use of assets and make the right business decision.
- **Predict**
Suggest the best maintenance date and reliability curve of installed assets based on real conditions to ensure OpEx savings.
- **Control**
Set up alerts and notify key personnel, and remotely implement an effective power management strategy to achieve energy savings in a simple way.

ABB Ability Electrical Distribution Control System enables the collection of electrical information from the ABB devices installed in the low-voltage power distribution panels. This innovative solution also provides access on a multi-site level, simultaneously monitoring and comparing the performance of different facilities. In addition, it can provide personal user profiles depending on the level of access they require.

ReliaGear neXT with Ekip Com hub

The SACE Tmax XT equipped with the new Ekip Com hub establishes the cloud connection for the entire panel. This dedicated cartridge-type communication module just needs to be inserted into the terminal box and connected to the Internet.

For more information, please visit <http://new.abb.com/low-voltage/launches/abb-ability-edcs>.

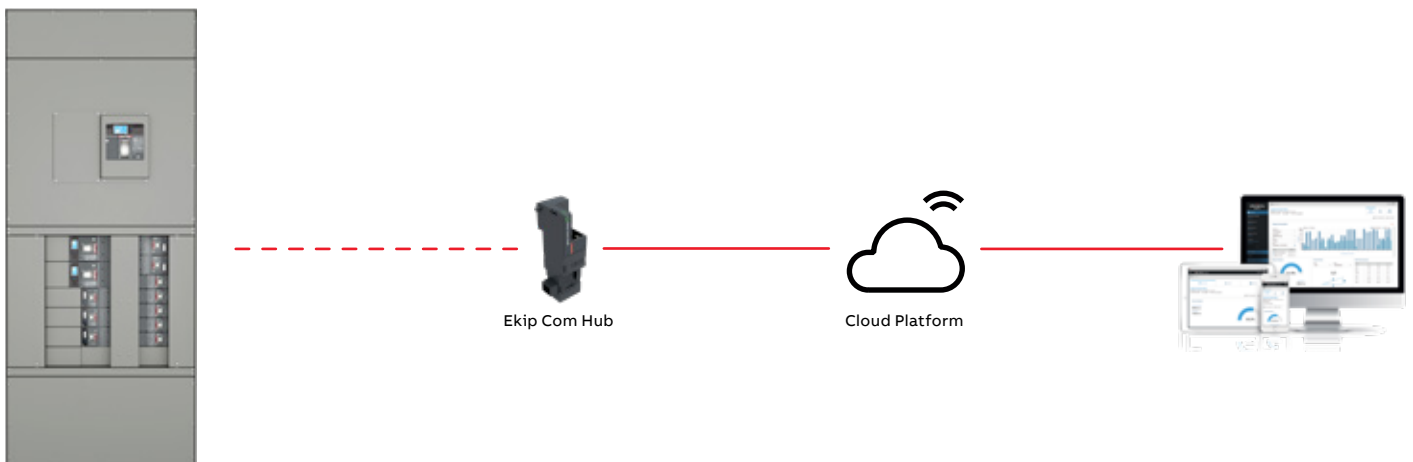



—

04

Panelboard selection guide/ numbering system

Panelboard selection guide/numbering system

Panelboard selection guide/numbering system	
XT breakers	56–57
TEY breakers	58–59
A2 breakers	58–59
FB breakers	60
Enclosure	60
Bus stack	61
Interior frame	61
Main lugs — Mechanical	62
Main lugs — Compression	62
Main lugs — Dual	63
Gutter covers	63
Fronts	64
Fillers and blanks	64
Barrier post	65
Vertical main kits	65
Vertical main rail kits	66
Door-in-door	66
Door-in-door filler	67
Door-in-door filler support	67
Grounds	68
Neutrals	68
Ground fault on feeder neutrals	69
Ground fault on feeder neutral current sensor kits	69
Neutral compression lugs	70
Service entrance/finger-safe barriers	70
Full IP20 main lug barrier	71
Horizontal mounting rail	71
Surge protection device (SPD)	72
RELT	72
Wire connector kit for RELT module	73
Single-point metering — RGM40	73
Single-point metering — AMP1	74
Meter current transformer kit	74
Meter CTs mounting kit	75
Drip hood	75
Submetering modules	76
Submetering CTs	76
Replacement parts	77

Catalog number scheme

XT breakers

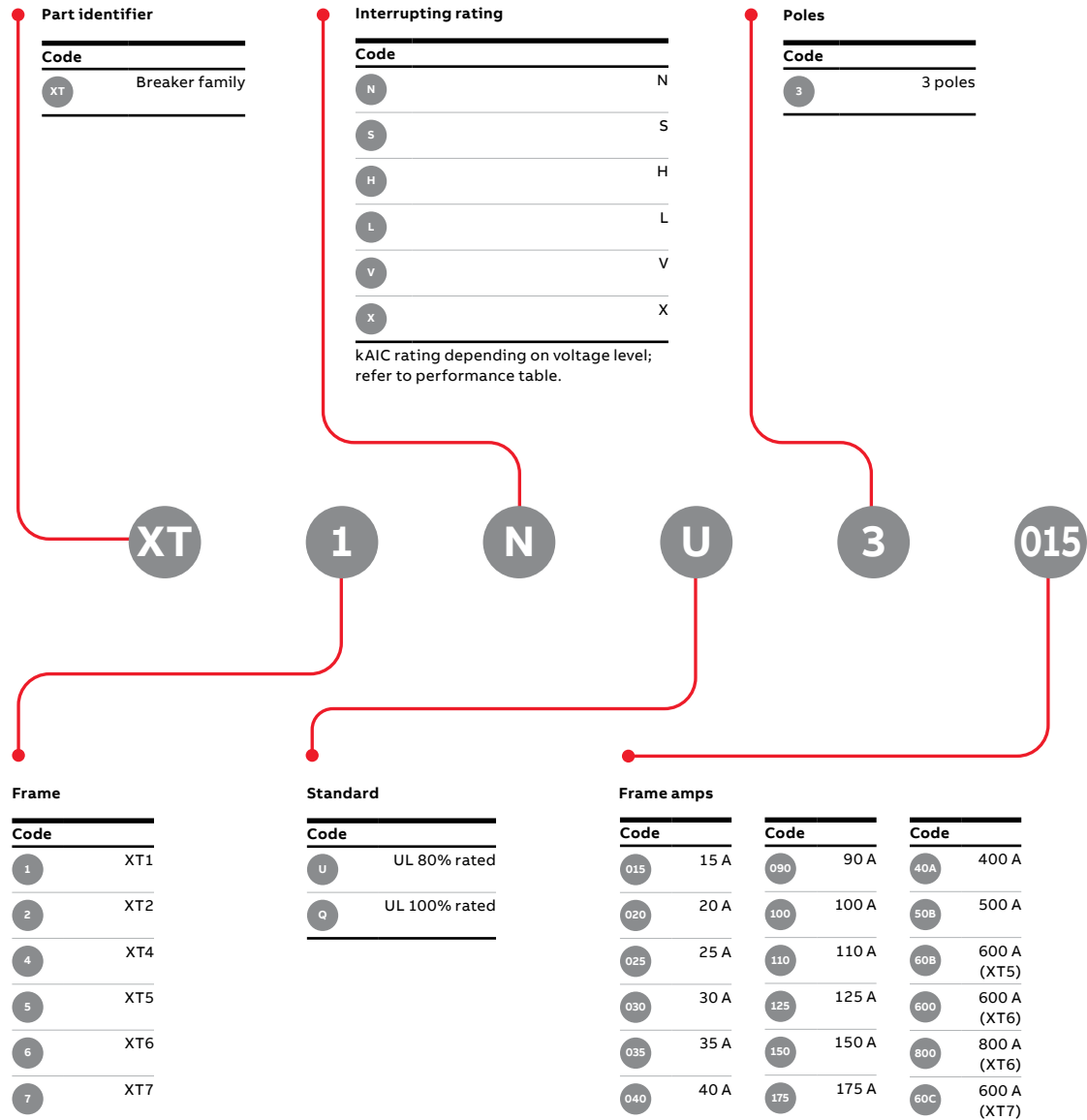

Note: Tmax XT MCCBs for ReliaGear neXT power panelboards and ReliaGear SB switchboards come with filler plates when ordered separately, except XT1. Tmax XT1 circuit breakers require a rail for installation in ReliaGear neXT power panelboards and ReliaGear SB switchboards if not already installed in your existing ReliaGear neXT or SB equipment. See table below for details on which XT1 group-mount rail kit is required.

	30" center	40" offset left	40" offset right	45" center	45" offset left	45" offset right
Single XT1	SR1XBR	SR1XBF	SR1XBR	SR1XBF	SR1XBF	SR1XBR
Two XT1 group-mount	SR2XBR	SR2XBF	SR2XBR	SR2XBF	SR2XBF	SR2XBR
Five XT1 group-mount	SR5XBR	SR5XBF	SR5XBR	SR5XBF	SR5XBF	SR5XBR

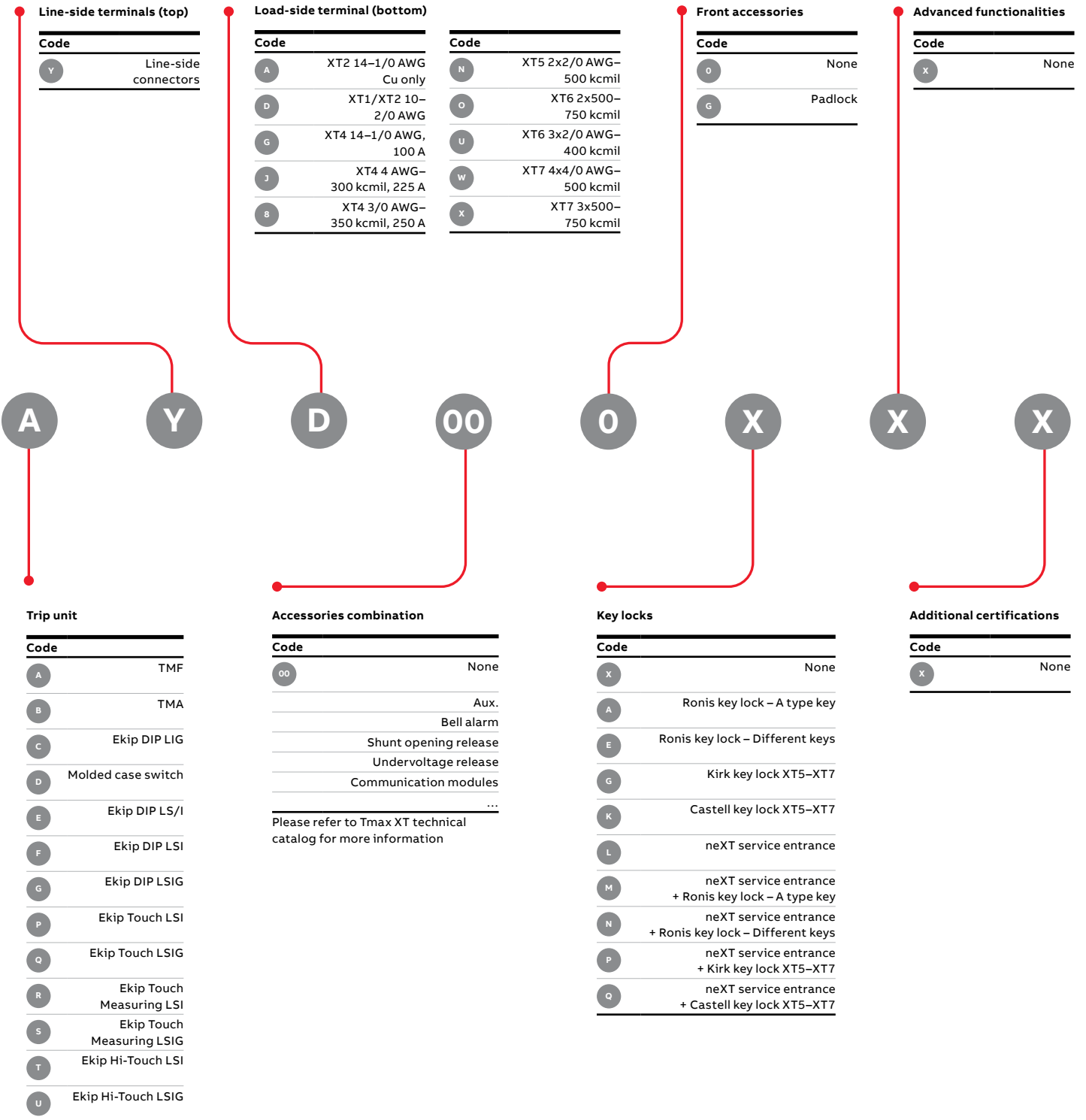

Catalog number scheme

TEY breakers



Note: TEY MCCBs for ReliaGear neXT power panelboards and ReliaGear SB switchboards come with filler plates when ordered separately.

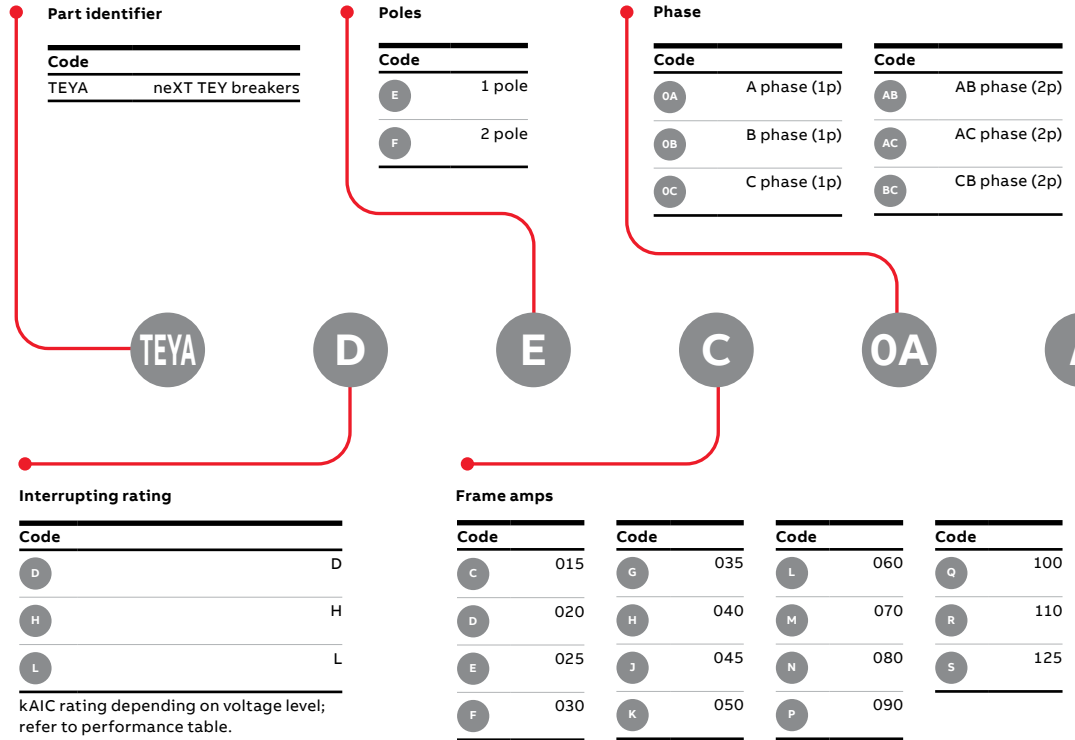

A2 breakers



Note: A2 MCCBs for ReliaGear neXT power panelboards and ReliaGear SB switchboards come with filler plates when ordered separately.

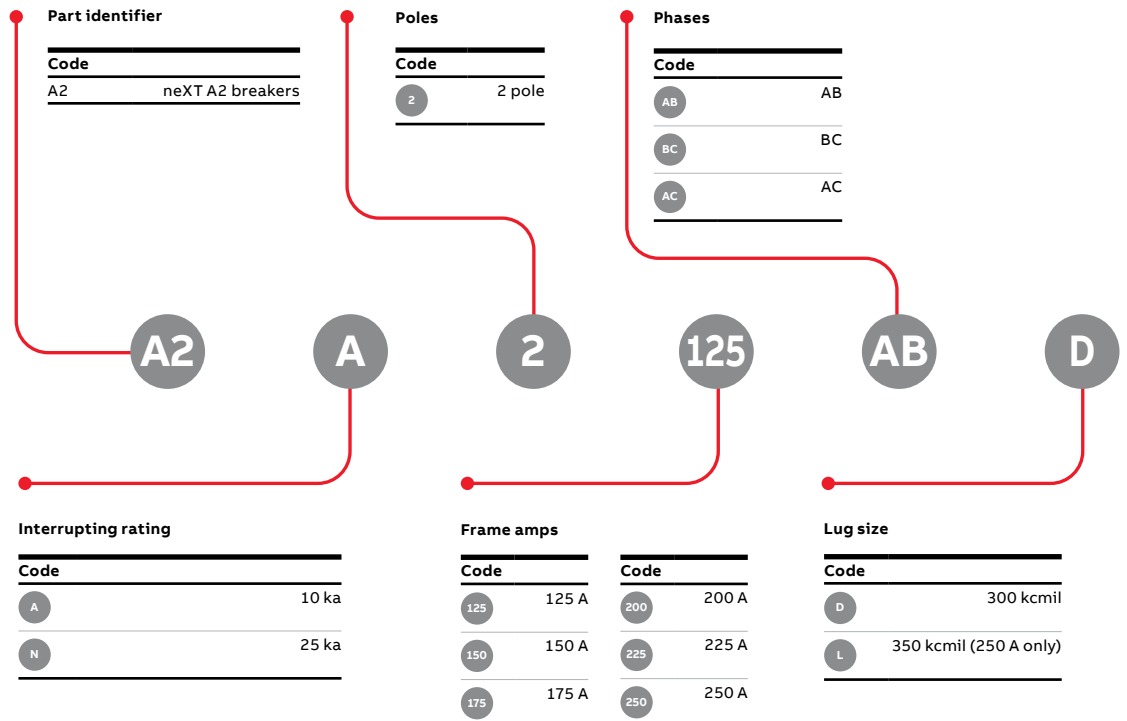

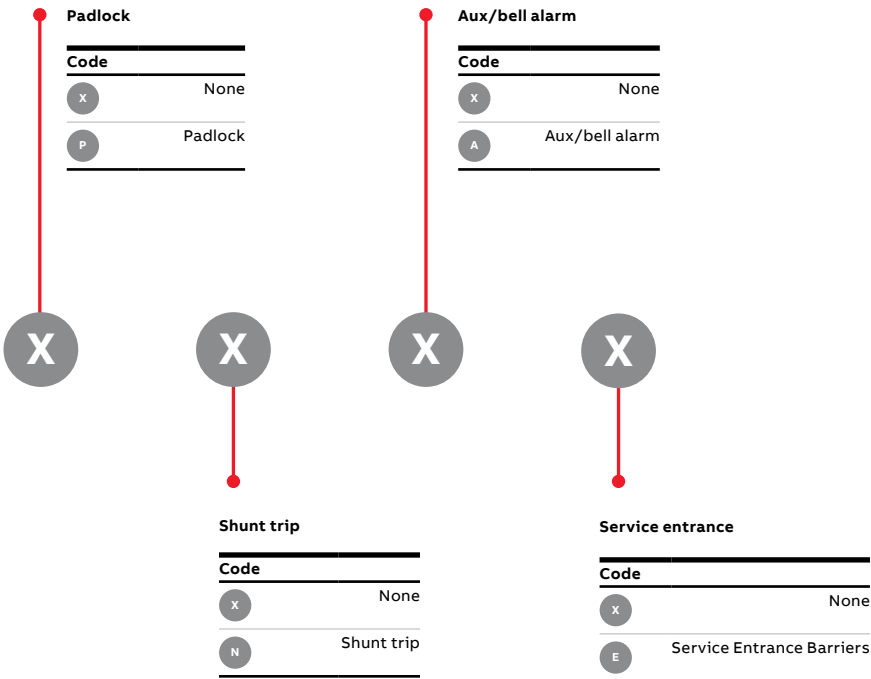
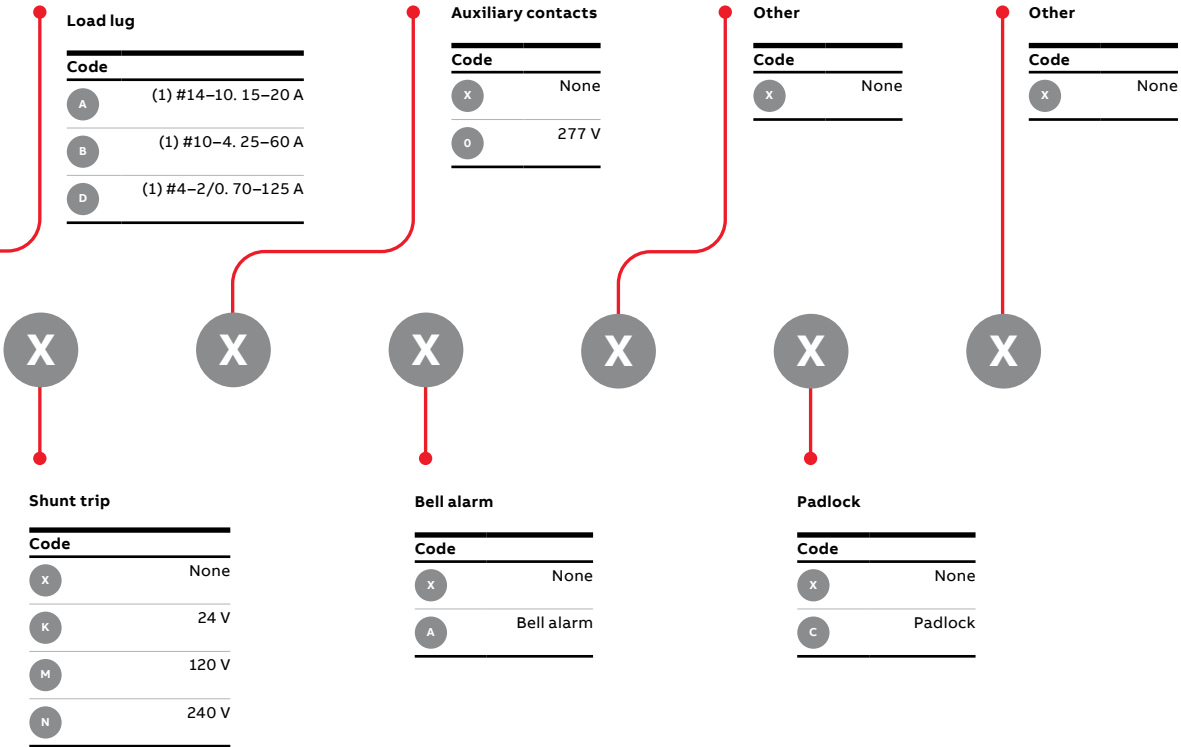

Catalog number scheme

FB breakers



Note: FB MCCBs for ReliaGear neXT power panelboards and ReliaGear SB switchboards come with filler plates when ordered separately.

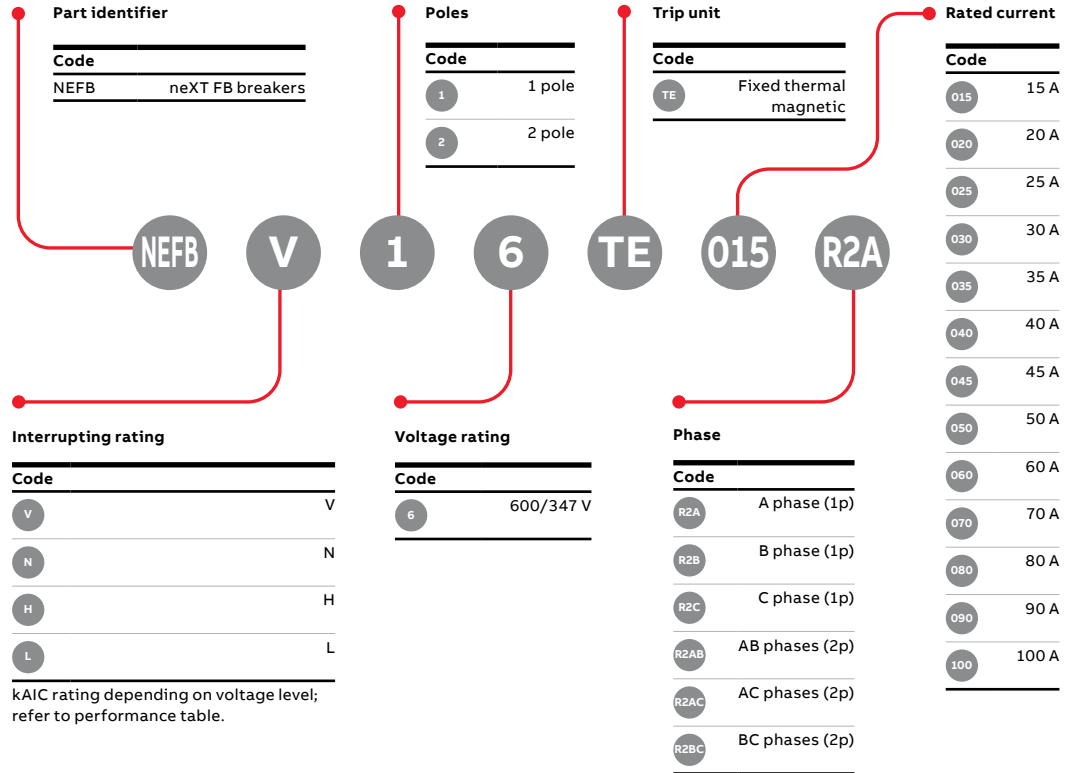

Enclosure

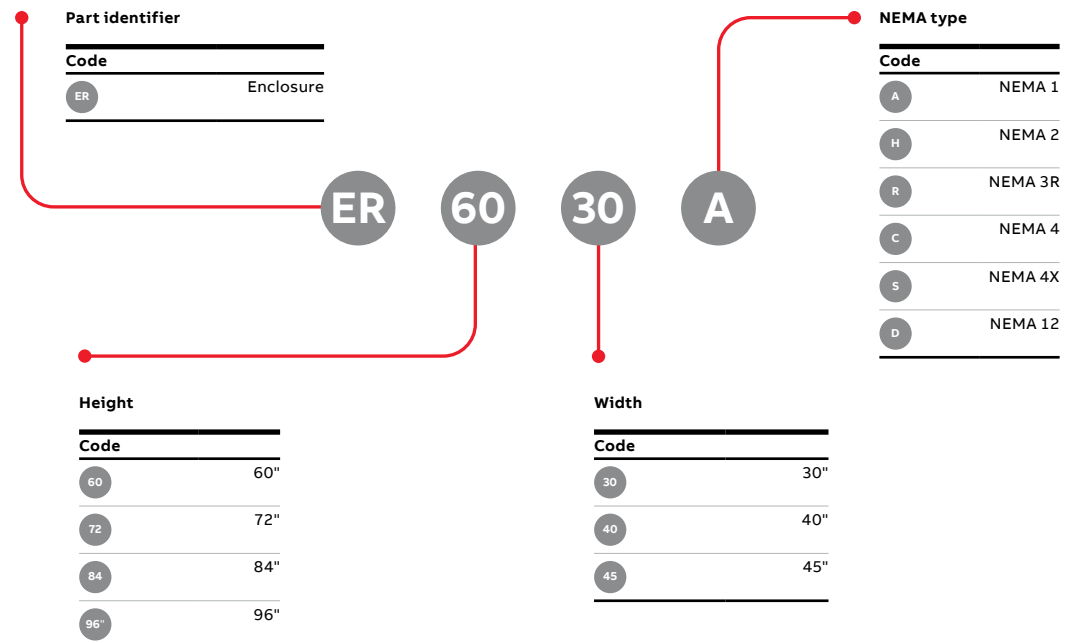

Catalog number scheme

Bus stack

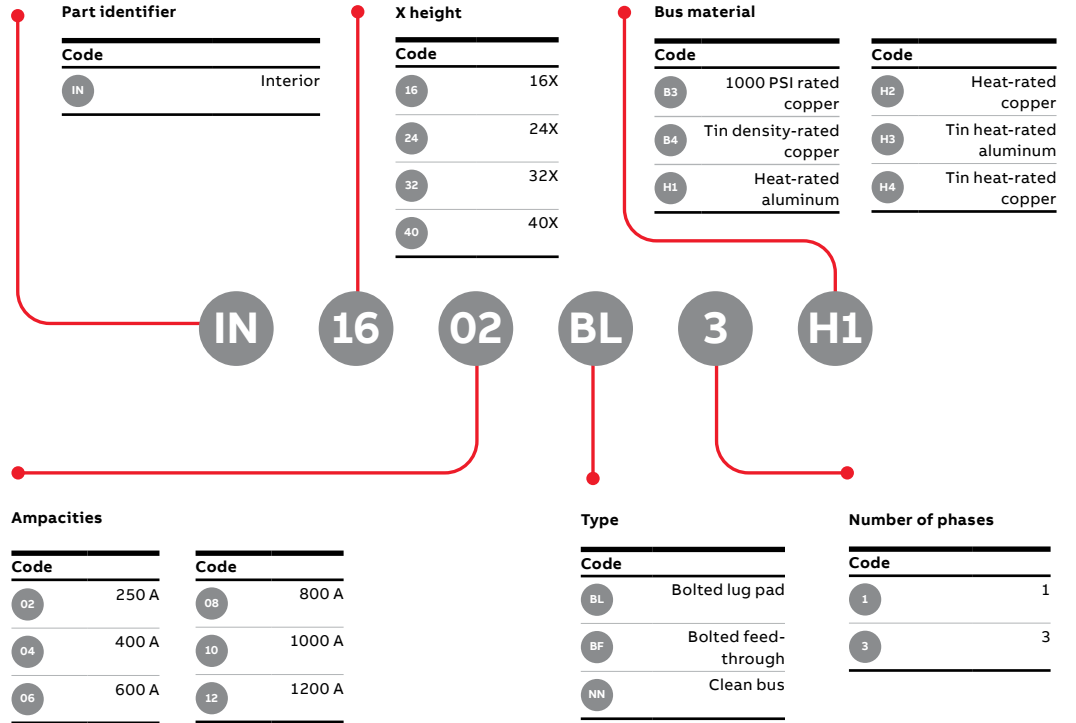

Interior frame

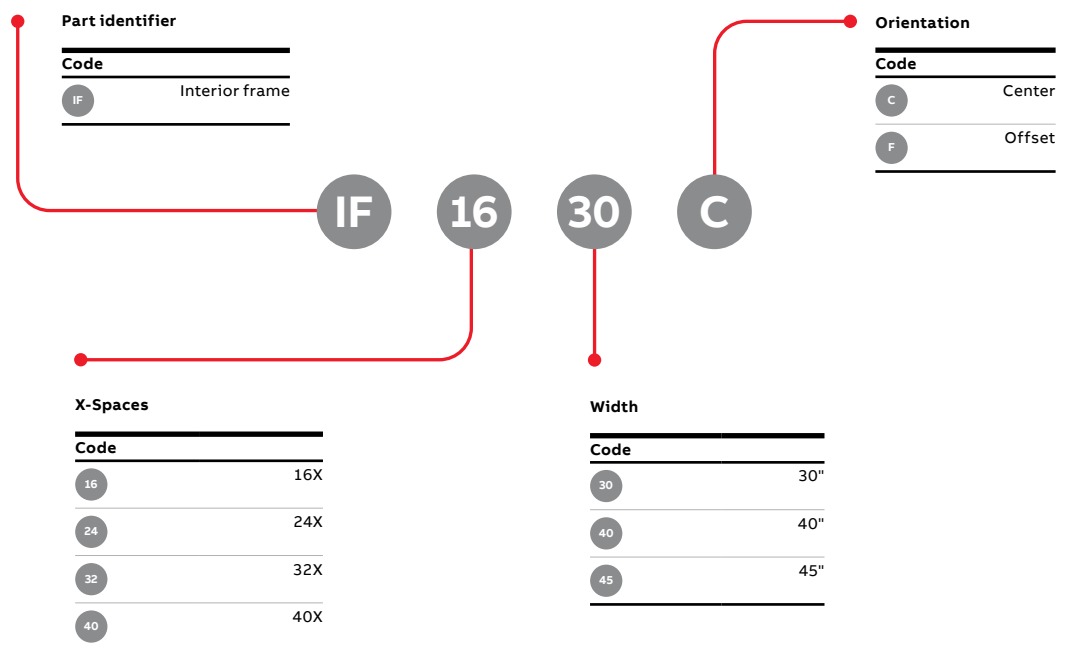

Catalog number scheme

Main lugs — Mechanical



Note: * Each catalog contains a single lug. The quantity should be multiplied by the number of phases (2X for single phase, 3X for 3 phase, and the quantity is doubled if feedthrough is needed). Also, this total quantity should be multiplied by 2 if there are 2 lugs needed per phase.

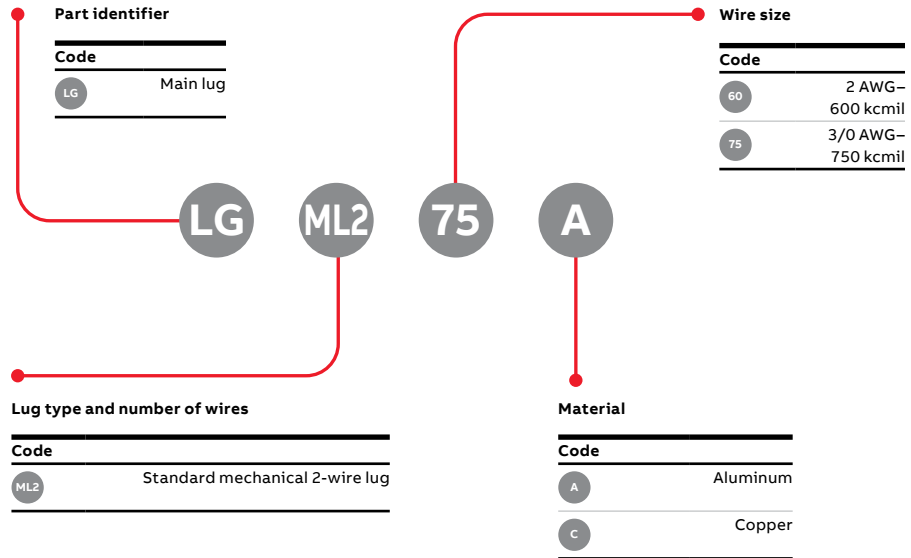

Main lugs — Compression



Note: * Each catalog generally contains the lugs for a single phase. The quantity should be multiplied by the number of phases (2X for single phase, 3X for 3 phase, and the quantity is doubled if feedthrough is needed).



Catalog number scheme

Main lugs — Dual



Note: * Each catalog contains all lugs/ components needed for Dual Main lugs. Quantity should always be 1.

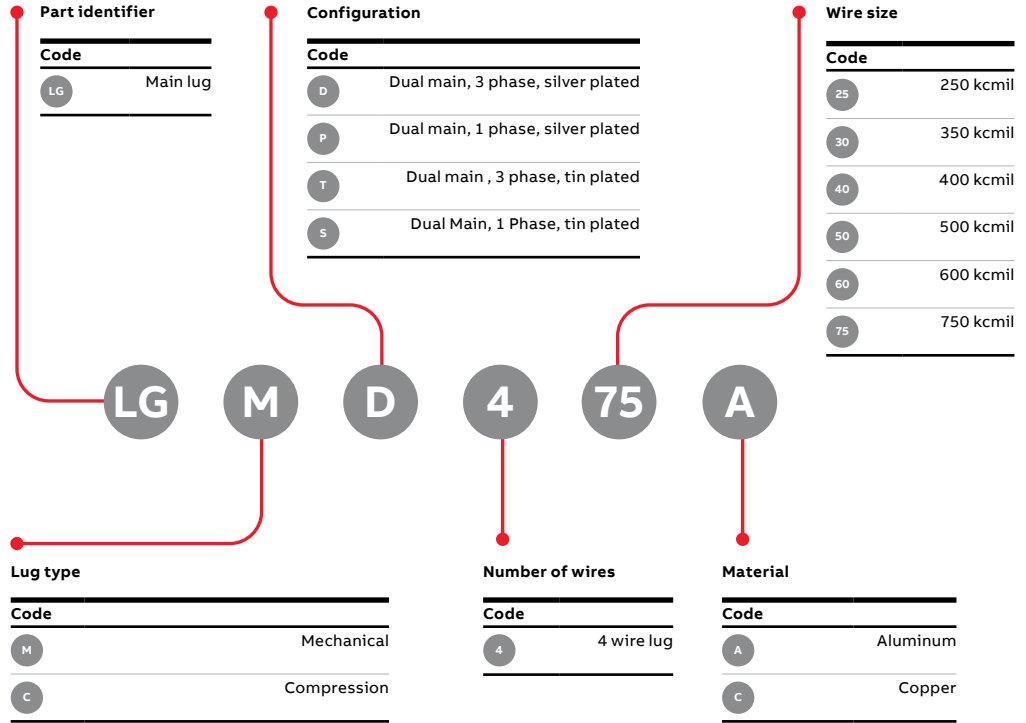

Gutter covers

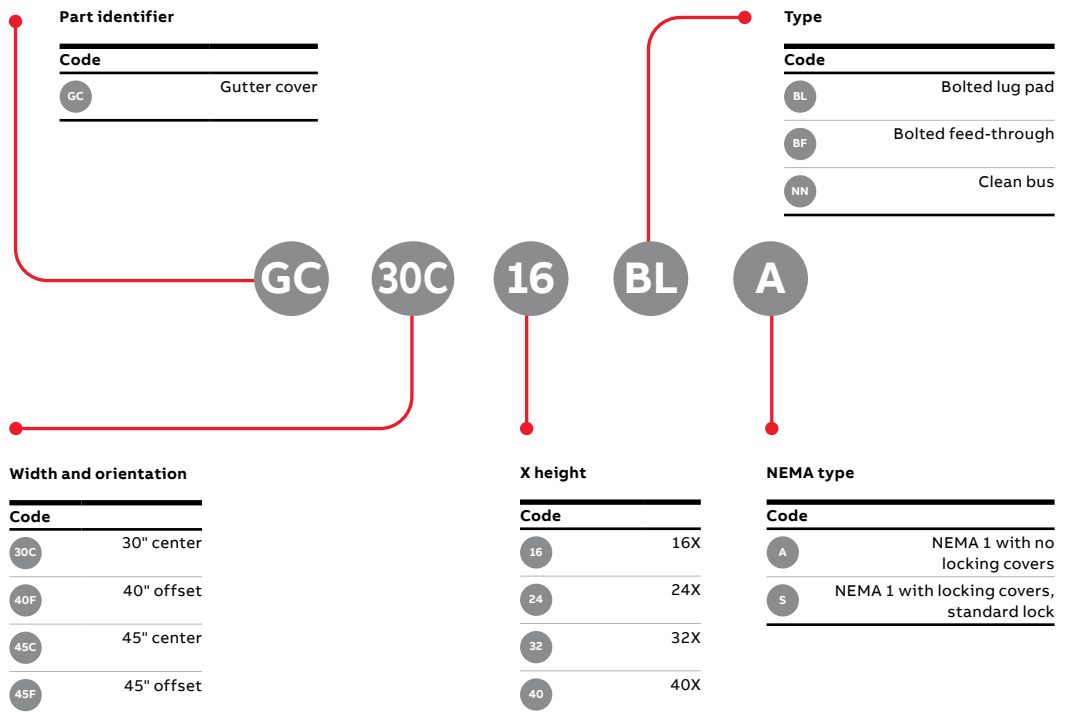

Catalog number scheme

Fronts



Note: Vented fronts to be used with 100% rated breakers.

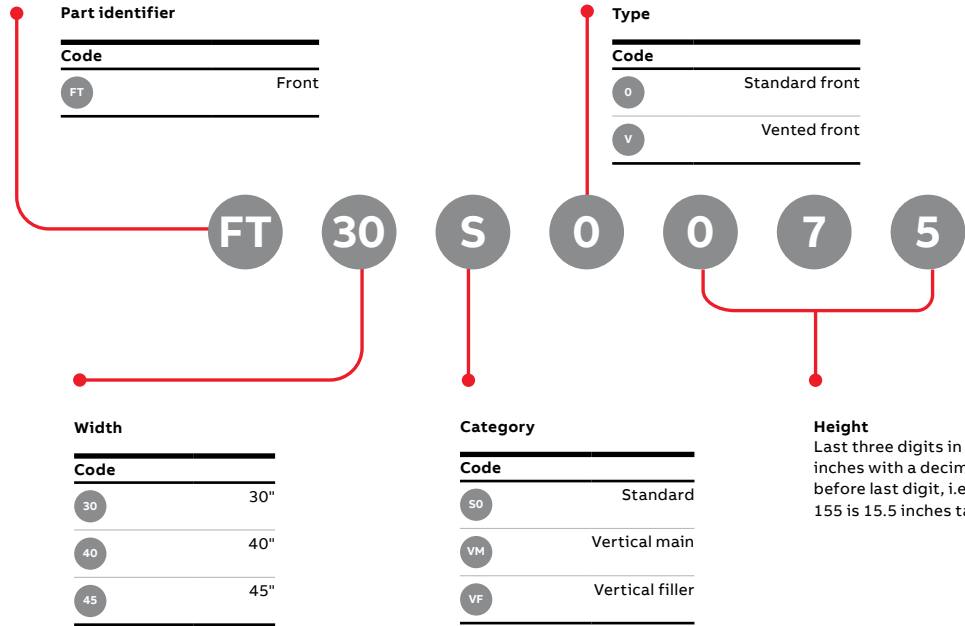

Fillers and blanks

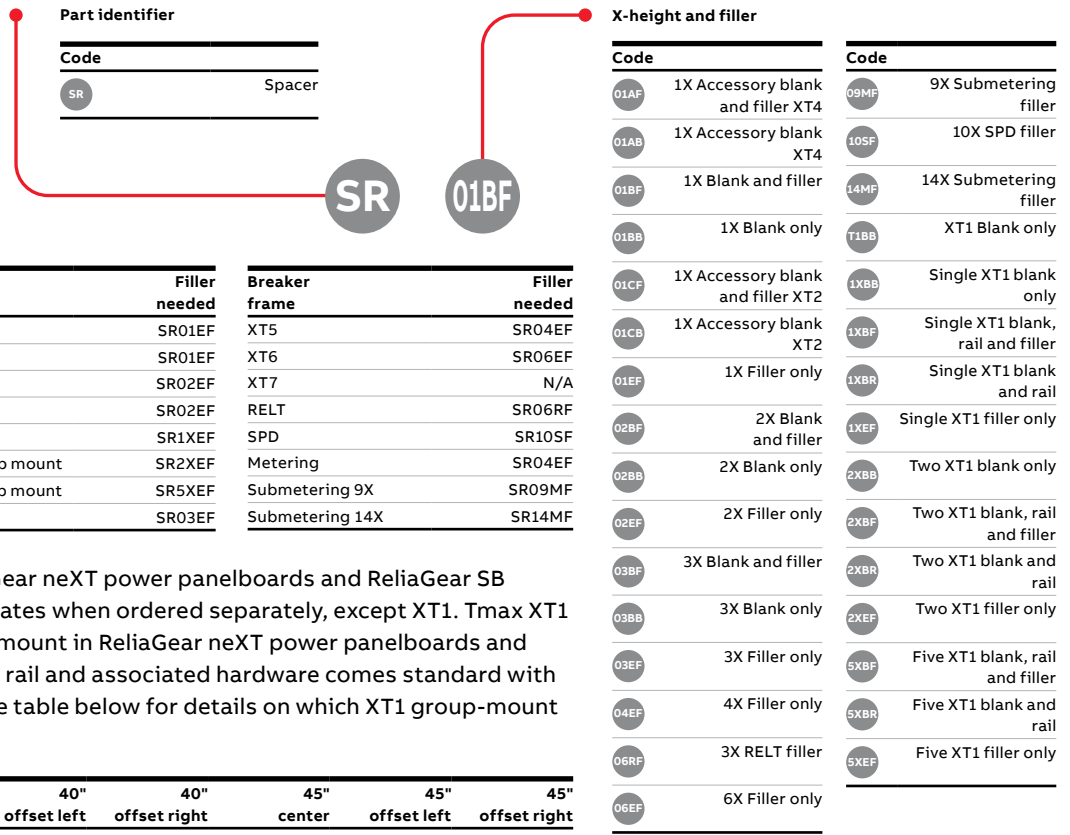

Note: Blank = A spacer to fill the area occupied by a circuit breaker when plugged into the interior bus stack.

Filler = A spacer to fill the area between a plugged-in circuit breaker and the gutter.

Note: Tmax XT MCCBs for ReliaGear neXT power panelboards and ReliaGear SB switchboards come with filler plates when ordered separately, except XT1. Tmax XT1 circuit breakers require a rail to mount in ReliaGear neXT power panelboards and ReliaGear SB switchboards. This rail and associated hardware comes standard with the different spacer options. See table below for details on which XT1 group-mount rail kit is required.

	30" center	40" offset left	40" offset right	45" center	45" offset left	45" offset right
Single XT1	SR1XBR	SR1XBF	SR1XBR	SR1XBF	SR1XBF	SR1XBR
Two XT1 group-mount	SR2XBR	SR2XBF	SR2XBR	SR2XBF	SR2XBF	SR2XBR
Five XT1 group-mount	SR5XBR	SR5XBF	SR5XBR	SR5XBF	SR5XBF	SR5XBR

Catalog number scheme

Barrier post

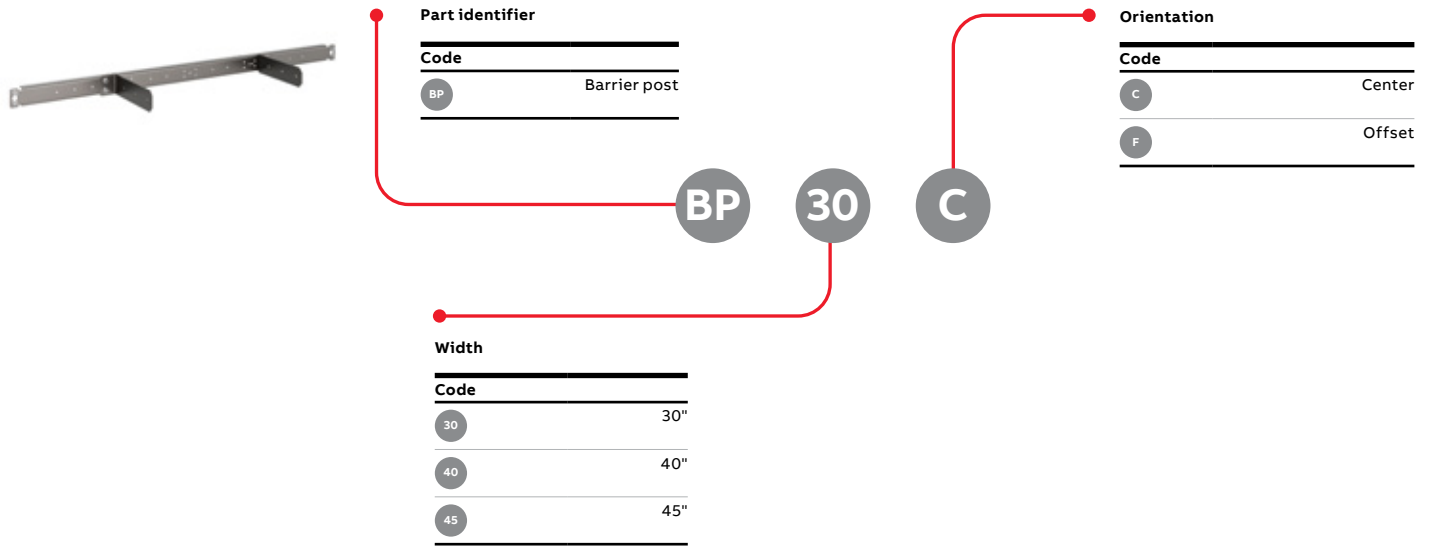

Vertical main kits

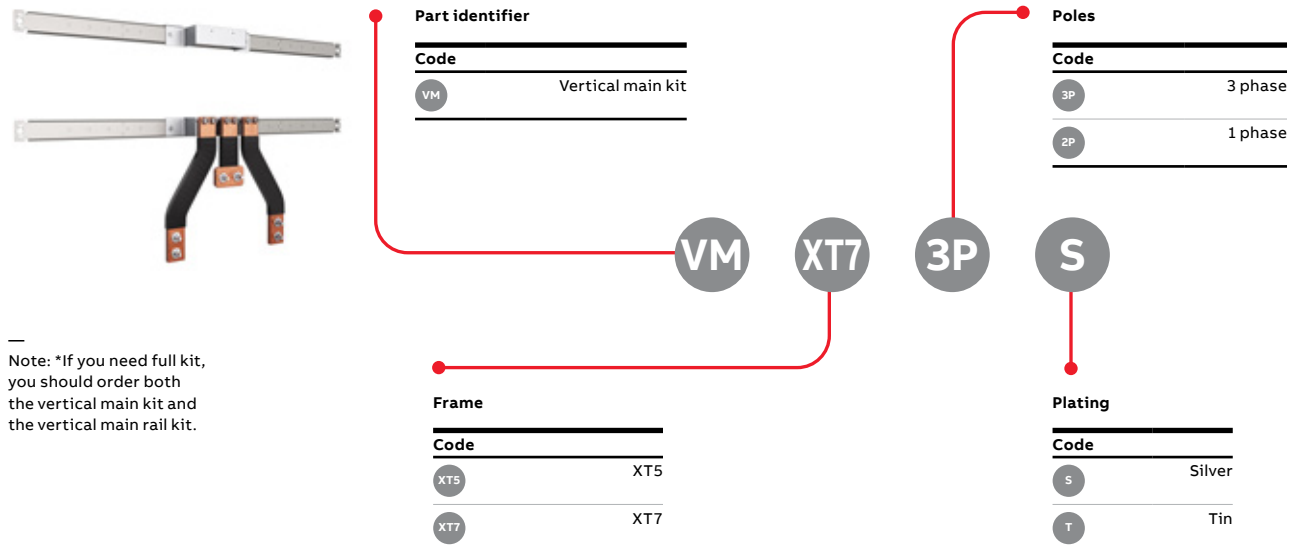

Note: *If you need full kit, you should order both the vertical main kit and the vertical main rail kit.

Catalog number scheme

Vertical main rail kits

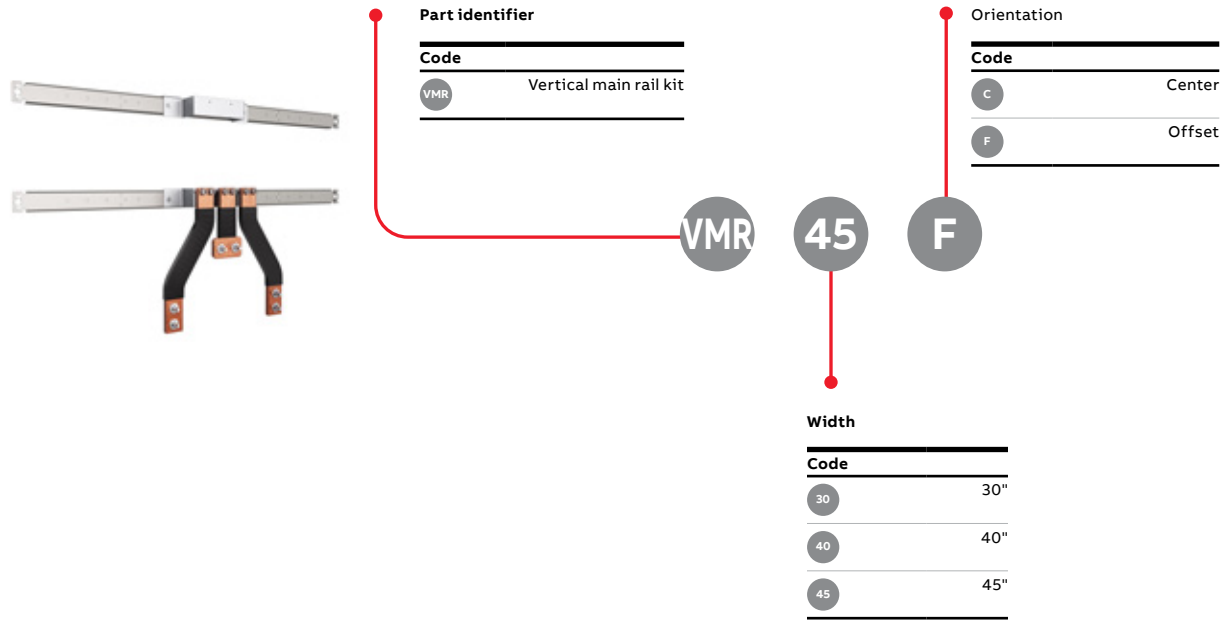

Door-in-door



Catalog number scheme

Door-in-door filler

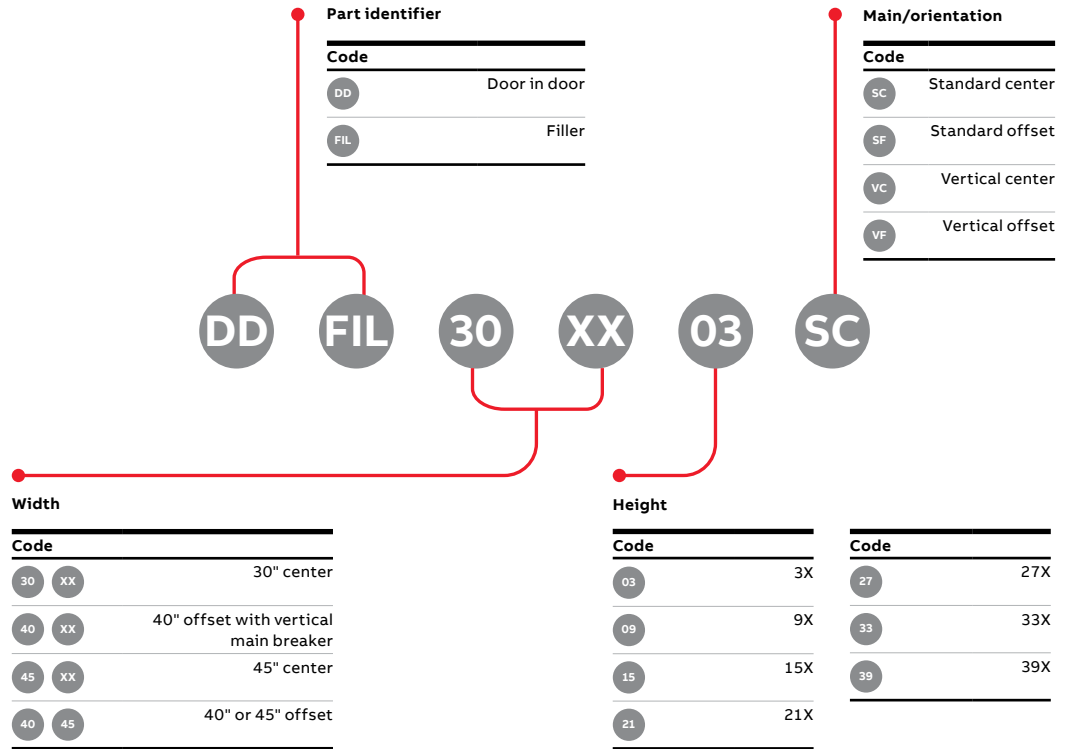

Door-in-door filler support

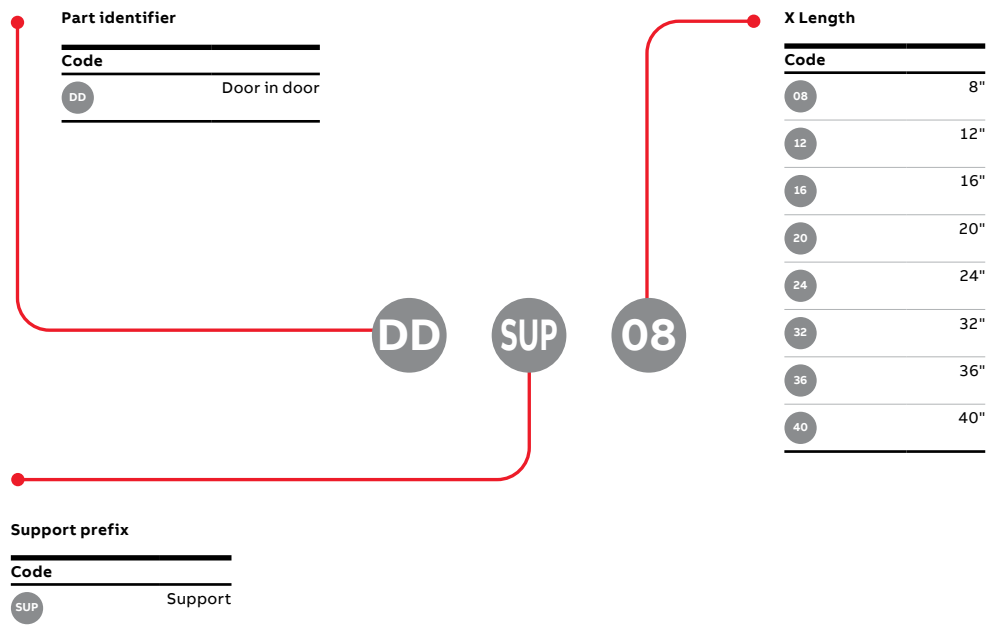

Catalog number scheme

Grounds

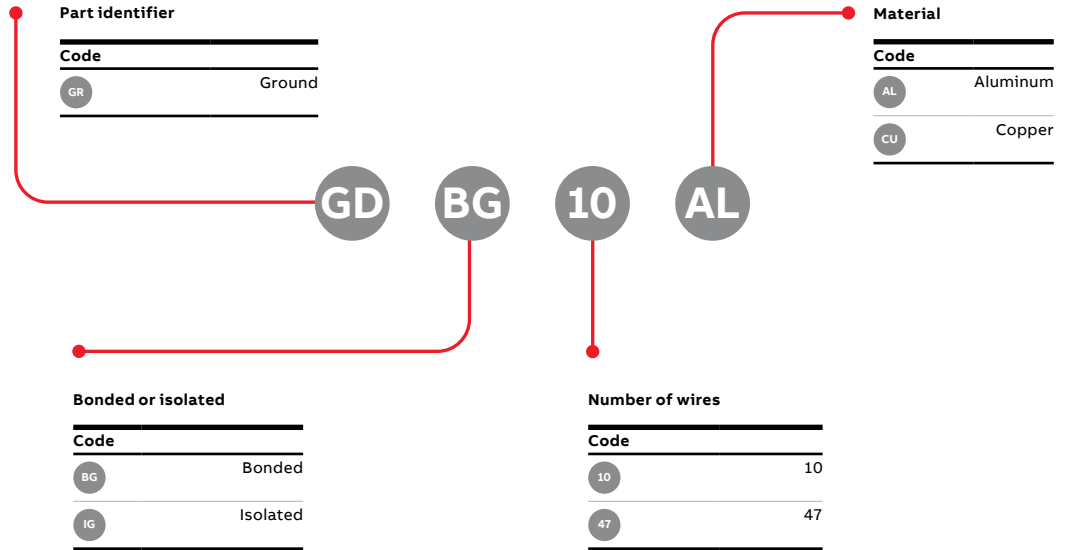

Neutrals

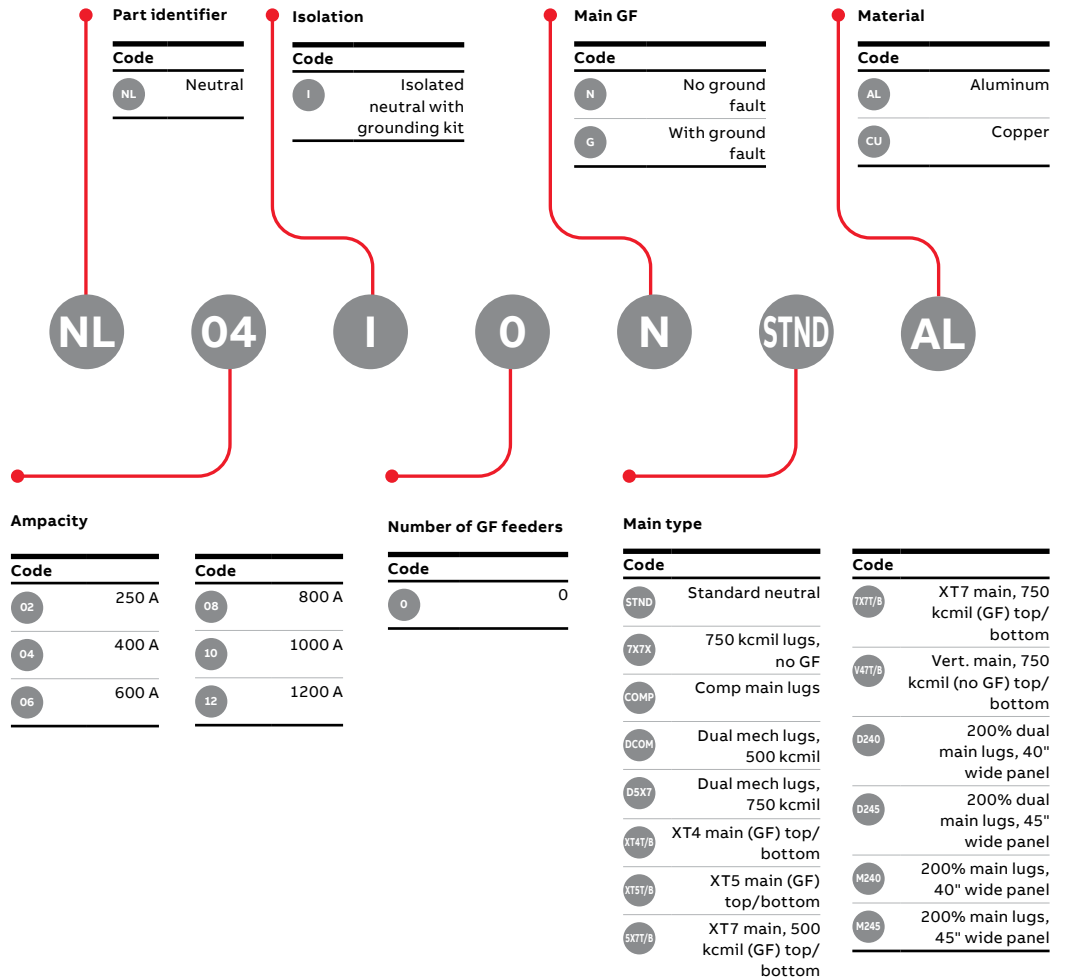

Note 1: All neutrals include a bonding kit
 Note 2: Neutral compression lugs required

Catalog number scheme

Ground fault on feeder neutrals

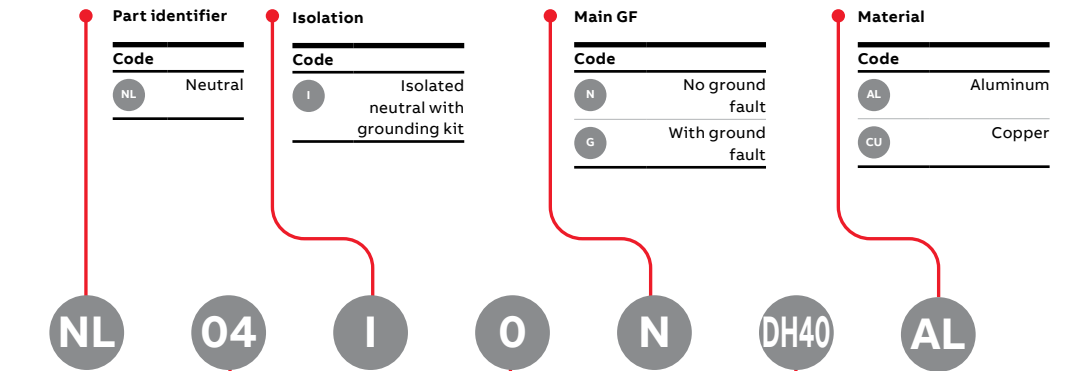

Part identifier

Code	
NL	Neutral

Isolation

Code	
I	Isolated neutral with grounding kit

Main GF

Code	
N	No ground fault
G	With ground fault

Material

Code	
AL	Aluminum
CU	Copper

Ampacity

Code		Code	
02	250 A	08	800 A
04	400 A	10	1000 A
06	600 A	12	1200 A

Number of GF feeders

Code	
0	0
4	4
6	6

Main type

Code		Code	
DH40	Dual mech main/horizontal main breaker, 40"W	5540	XT5 main, 500 kcmil (GF), 40"W
MH40	Main lug/horizontal main breaker, 40"W	5545	XT5 main, 500 kcmil (GF), 45"W
DH45	Dual mech main/horizontal main breaker, 45"W	7540	XT5 main, 750 kcmil (GF), 40"W
MH45	Main lug/horizontal main breaker, 45"W	7545	XT5 main, 750 kcmil (GF), 45"W
X440	XT4 main (GF), 40"W	5745	XT7 main, 500 kcmil (GF), 45"W
X445	XT4 main (GF), 45"W	7745	XT7 main, 750 kcmil (GF), 45"W

Note: These ground fault neutrals are not orderable as loose units, only factory assembled.

Ground fault on feeder neutral current sensor kits

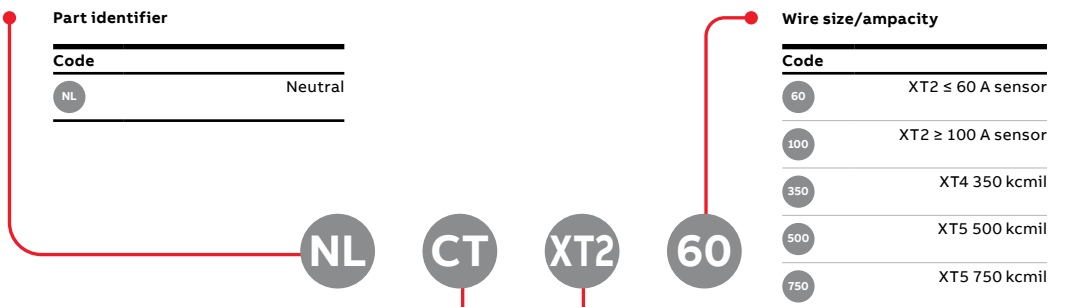

Part identifier

Code	
NL	Neutral

Wire size/ampacity

Code	
60	XT2 ≤ 60 A sensor
100	XT2 ≥ 100 A sensor
350	XT4 350 kcmil
500	XT5 500 kcmil
750	XT5 750 kcmil

Current sensor

Code	
CT	Current sensor

Breaker frame

Code	
XT2	XT2
XT4	XT4
XT5	XT5

Note: These ground fault on feeder neutral current sensor kits are not orderable as loose units, only factory assembled.

Catalog number scheme

Neutral compression lugs



Part identifier

Code	Description
LGN	Neutral compression lug

Wire size

Code	Wire size
010	1/0
020	2/0
030	3/0
040	4/0
250	250 kcmil
300	300 kcmil
350	350 kcmil
400	400 kcmil
500	500 kcmil
600	600 kcmil
750	750 kcmil

LGN 750

Service entrance/finger-safe barriers



Part identifier

Code	Description
SB	Service entrance barrier

Number of poles

Code	Number of poles
P3	3
P2	2

SB X1 W35 P3

Breaker frame

Code	Frame
X1	XT1
X2	XT2
X4	XT4
X5	XT5
X6	XT6
X7	XT7
A2	A2

Wire size

Code	Wire size
W02	2/0 AWG
WT2	2/0 AWG XT2 thermo mag
WE2	2/0 AWG XT2 electronic
W30	300 kcmil

Wire size

Code	Wire size
W35	350 kcmil
W40	400 kcmil
W50	500 kcmil
W75	750 kcmil

Catalog number scheme

Full IP20 main lug barrier

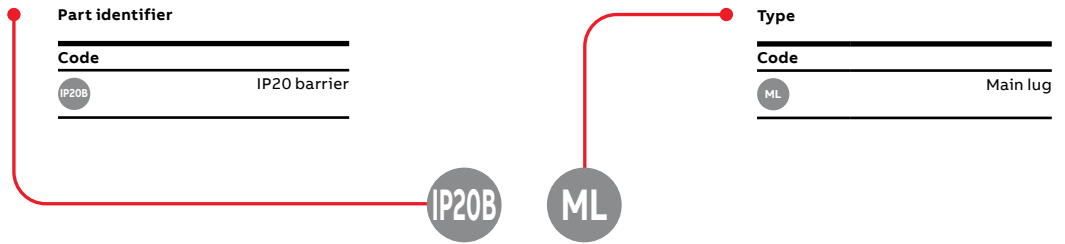
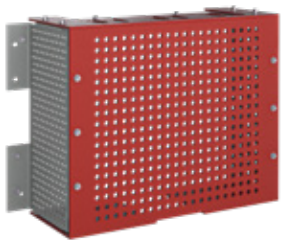

Horizontal mounting rail

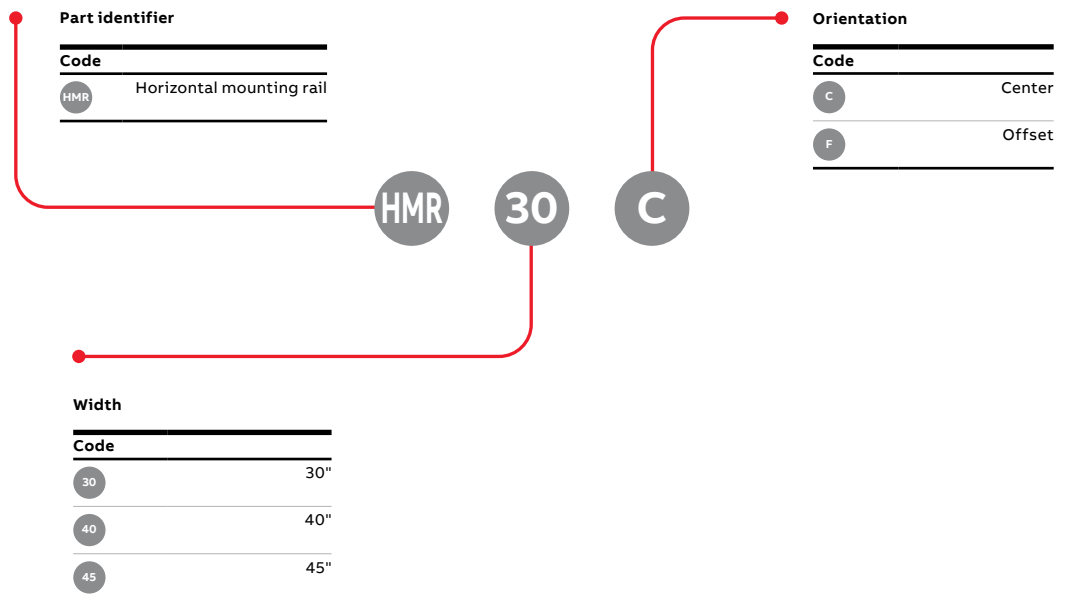

Catalog number scheme

Surge protection device (SPD)



Note: SPDs come with filler plate when ordered separately.

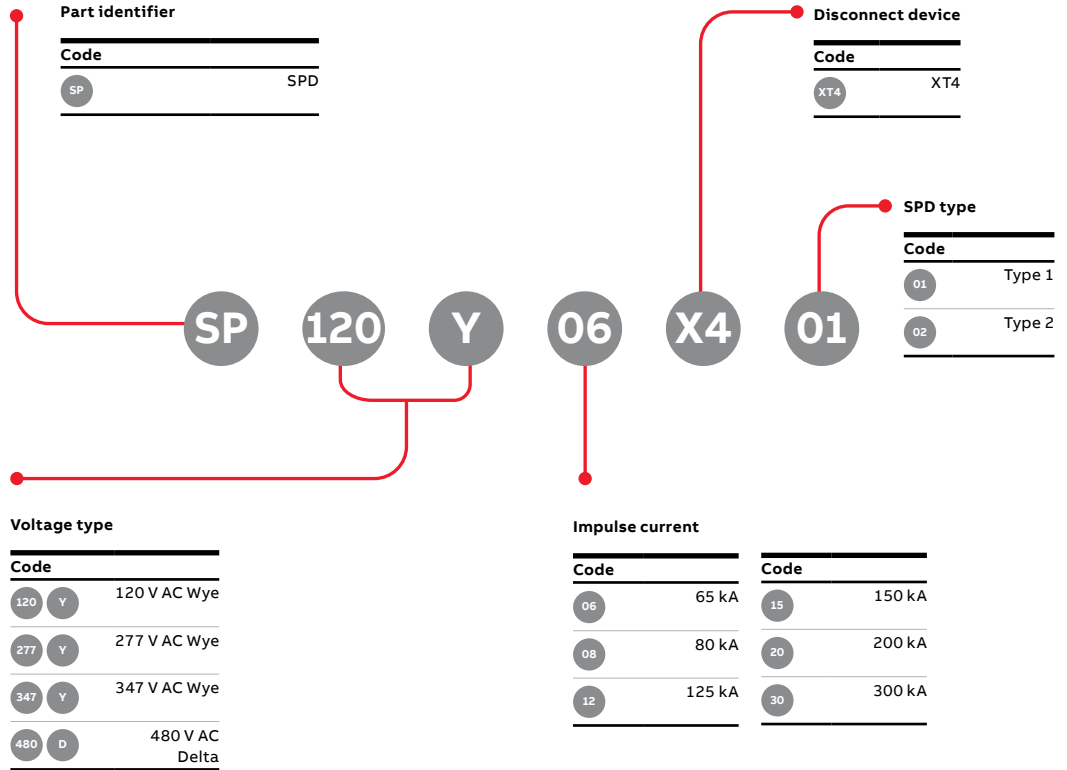

RELT



Notes: RELT is available for the 40"W and 45"W enclosures only.
 When RELT is ordered separately:
 • For XT7, Ekip supply and Ekip signaling 2k are also needed — see wire connector kits for RELT module.
 • RELT comes with filler plate.

When RELT is ordered with configured panel:
 • For XT7, Ekip supply and Ekip signaling 2k are also supplied in a CN series wire connector kit.

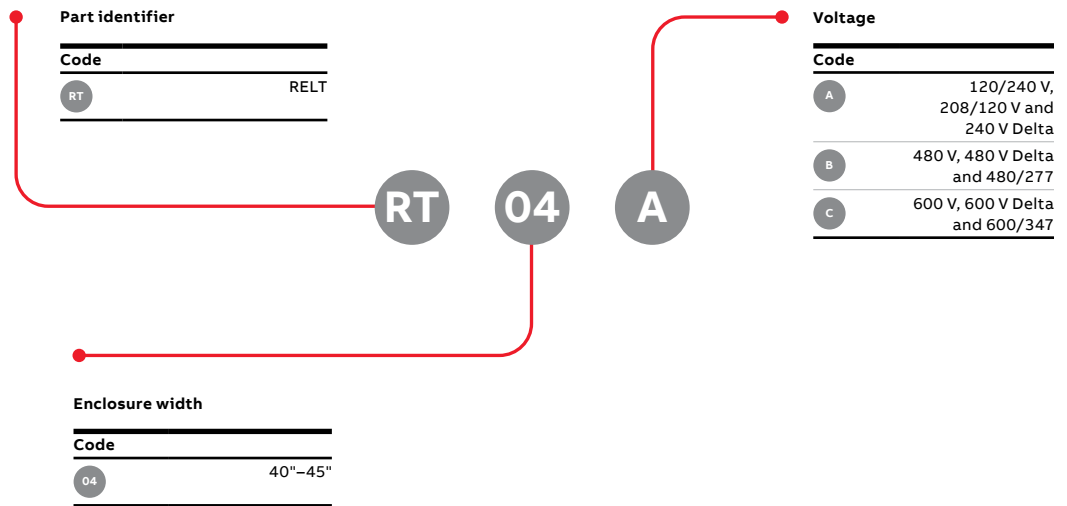

Catalog number scheme

Wire connector kit for RELT module

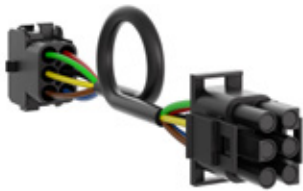

Notes: For replacement wire connector kits, an exact replacement must be used (i.e., a 2K-1 kit must be used to replace an existing 2K-1 kit). Failure to do so may result in incorrect RELT functionality or require the breaker to be re-programmed. Refer to 9AKK107991A2520 and 1SQC900005M0201 for more information.

CN003 includes Ekip 2K-1 signaling and Ekip supply. CN004 includes Ekip 2K-3 signaling and Ekip supply. CN004 is ONLY compatible with firmware version 3.10.00 or higher. Refer to 9AKK107991A2520 to validate firmware version.

CN001 is a cable extension for use with XT7 vertical mains.

When vertical main is used, you must order CN001 and CN003 or CN001 and CN004.

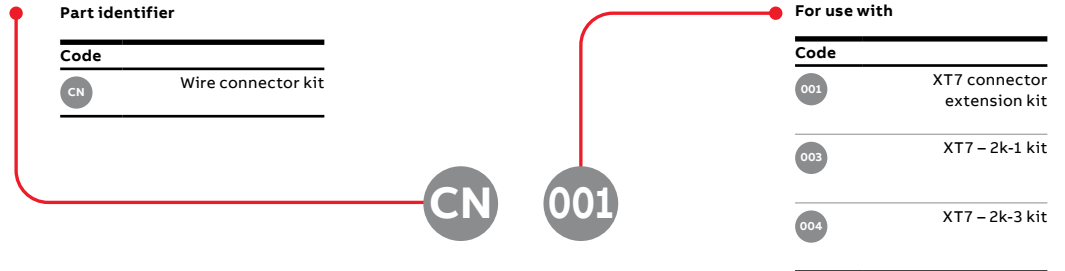

Single-point metering — RGM40



Note: Please also select a current transformer kit and a mounting kit. Single-point meters come with filler plate when ordered separately.

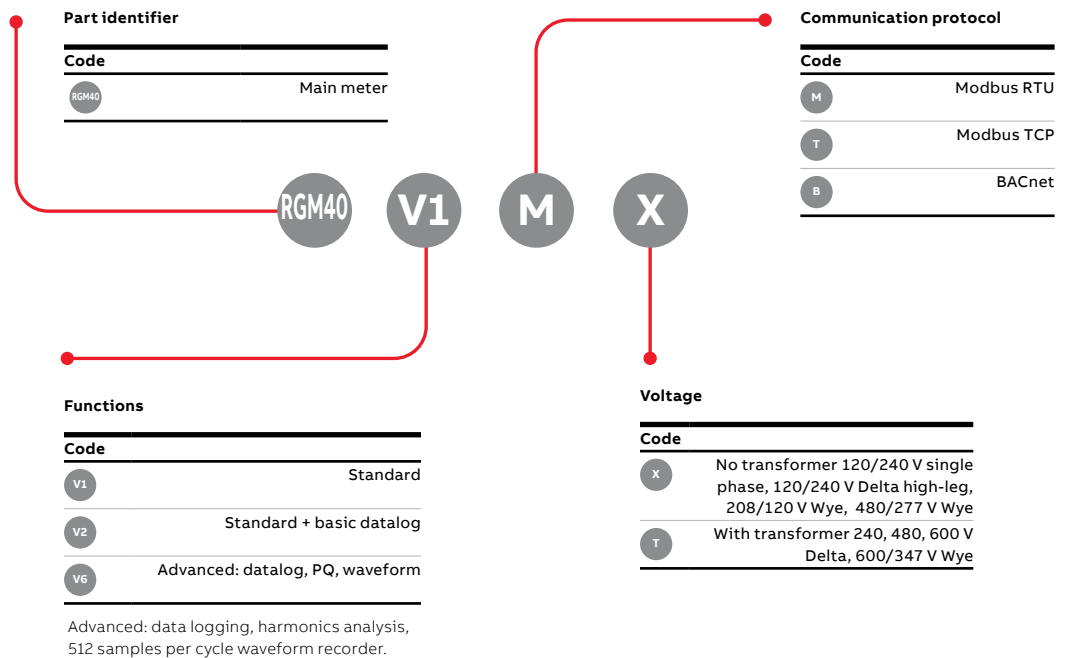

Catalog number scheme

Single-point metering — AMP1



Part identifier

Code	
MT	Single-point metering – AMP1

MT

04

AP

Meter options

Code	
AP	Pulse
AM	AMP1, Modbus
AD	AMP1, Modbus data log
AB	AMP1, BACnet

Enclosure width

Code	
04	40"–45"

Notes: Please also select a current transformer kit and a mounting kit. Single-point meters come with filler plate when ordered separately.

Meter current transformer kit



Part identifier

Code	
MT	Meter current transformer kit

MT

A

03

02

CT

Ampacity

Code	
02	250 A
04	400 A
06	600 A
08	800 A
10	1000 A
12	1200 A

Meter used

Code	
A	AMP1

Phase

Code	
03	3-phase

CT designation

Code	
CT	For CTs only

Catalog number scheme

Meter CTs mounting kit

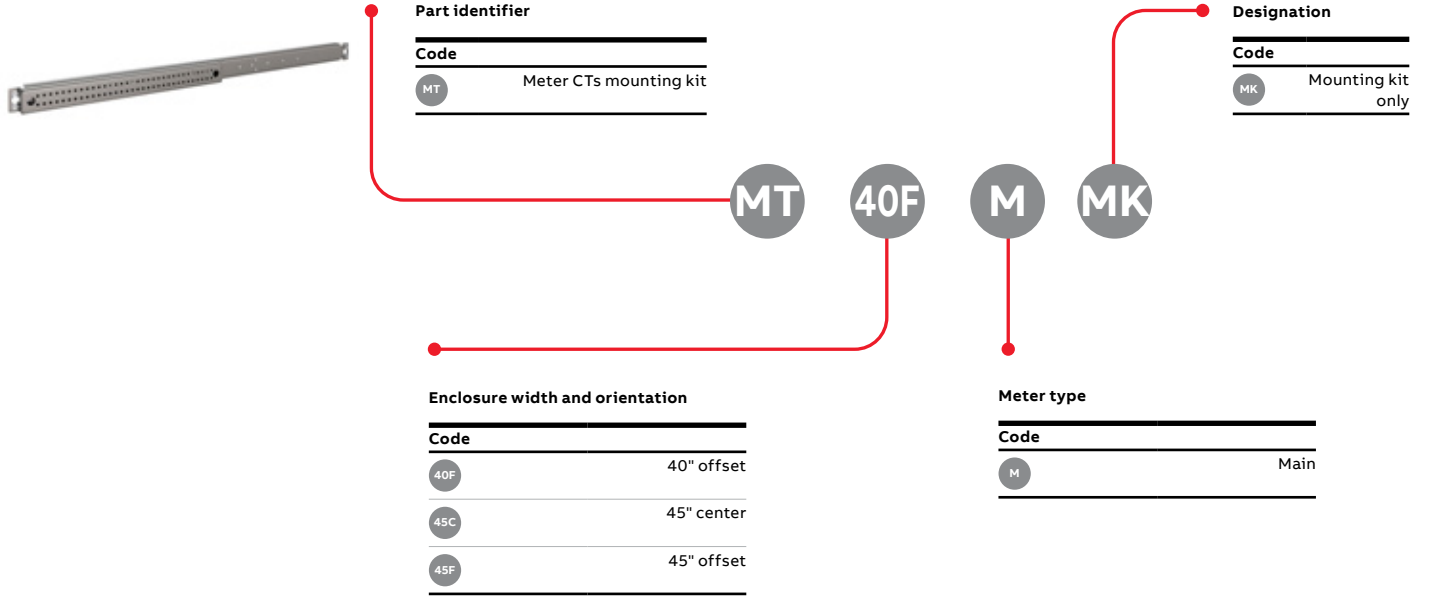

Drip hood

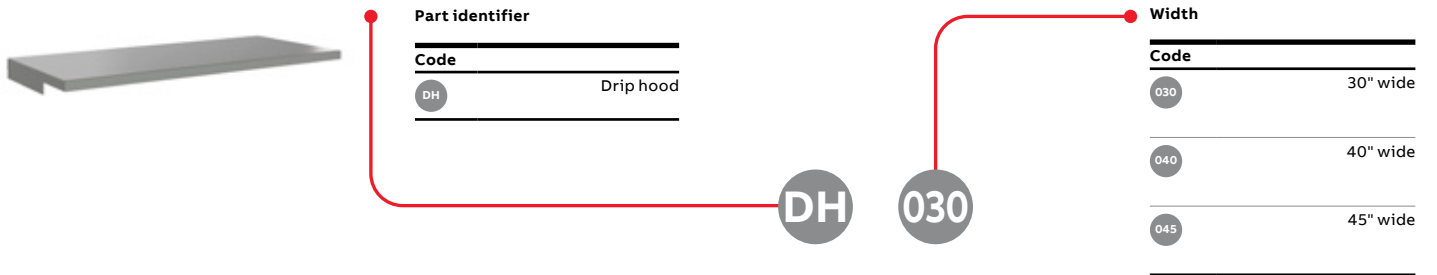

Catalog number scheme

Submetering modules



Note: *Qbrick 6 can only be used on 240V and lower circuits.

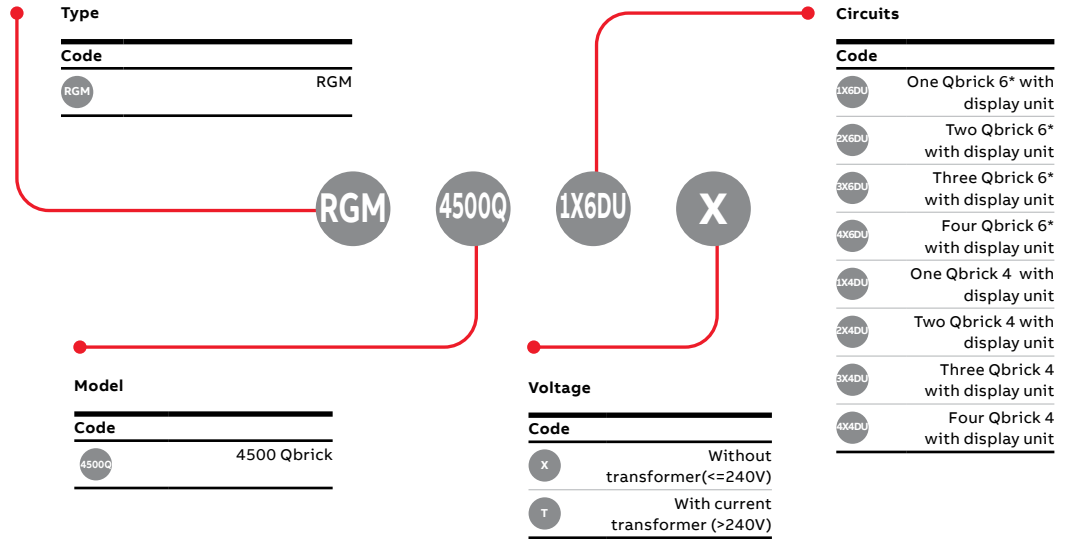

Submetering CTs

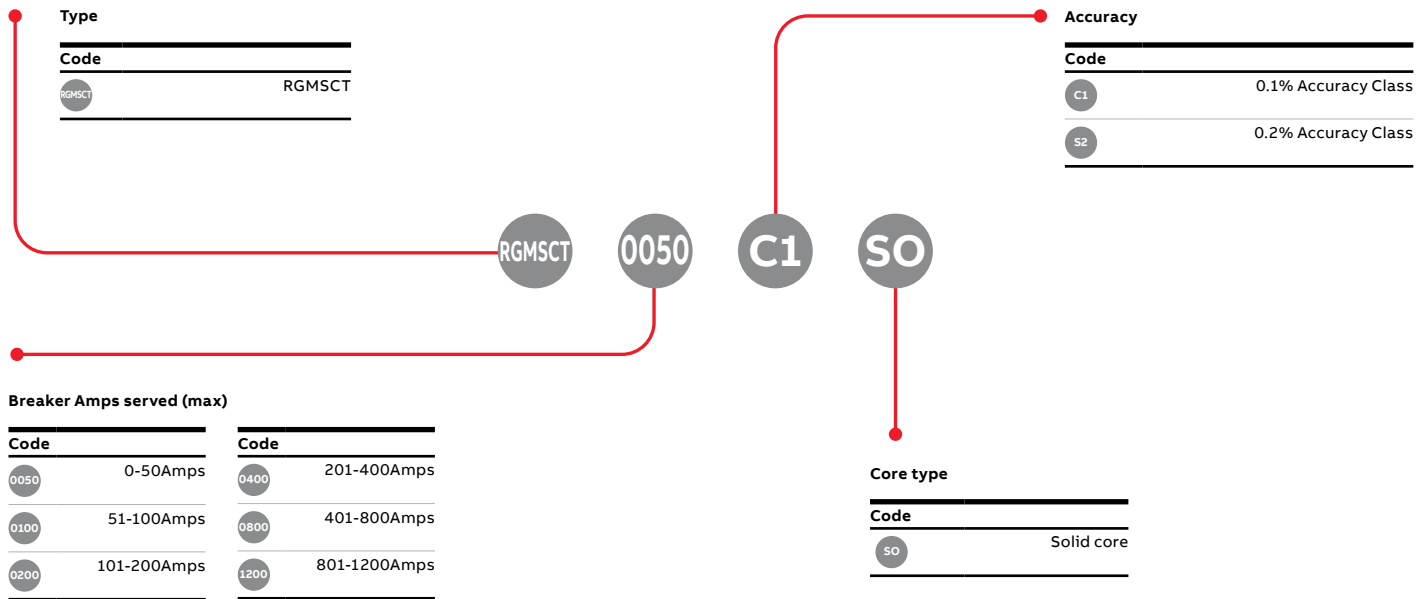

Note: These submetering components are not orderable as loose units, only available through factory assembled option, no Bulk Pack.

Catalog number scheme

Replacement parts

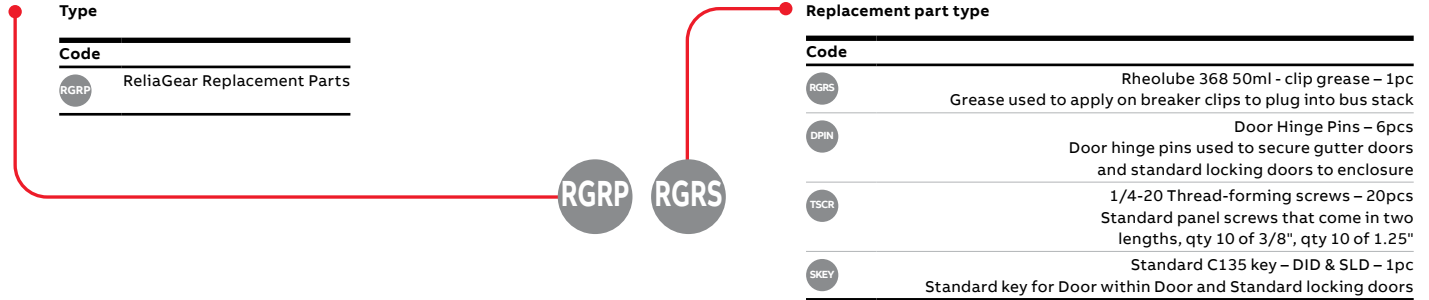

Note: For additional information, please refer to the replacement parts instruction sheet [1SQ900015M0201](#)



—

US

ABB Inc.
305 Gregson Drive
Cary, NC 27511

new.abb.com/low-voltage/launches/reliagear-next

—

We reserve the right to make technical changes or modify the contents of this document without prior notice. With regard to purchase orders, the agreed particulars shall prevail. ABB Inc does not accept any responsibility whatsoever for potential errors or possible lack of information in this document.

We reserve all rights in this document and in the subject matter and illustrations contained therein. Any reproduction, disclosure to third parties or utilization of its contents – in whole or in parts – is forbidden without prior written consent of ABB Inc. © Copyright 2024 ABB. All rights reserved. Specifications subject to change without notice.