



The information contained in this document is subject to change without notice and may not be suitable for all applications. While every precaution has been taken to ensure the accuracy and completeness of this document, Vertiv assumes no responsibility and disclaims all liability for damages result from use of this information or for any errors or omissions.

Refer to local regulations and building codes relating to the application, installation, and operation of this product. The consulting engineer, installer, and/or end user is responsible for compliance with all applicable laws and regulations relation to the application, installation, and operation of this product.

The products covered by this instruction manual are manufactured and/or sold by Vertiv. This document is the property of Vertiv and contains confidential and proprietary information owned by Vertiv. Any copying, use, or disclosure of it without the written permission of Vertiv is strictly prohibited.

Names of companies and products are trademarks or registered trademarks of the respective companies. Any questions regarding usage of trademark names should be directed to the original manufacturer.

## **Technical Support Site**

If you encounter any installation or operational issues with your product, check the pertinent section of this manual to see if the issue can be resolved by following outlined procedures.

Visit for additional assistance.

## TABLE OF CONTENTS

1 Important Safety Instructions .....	1
2 Introduction .....	1
2.1 General Information .....	1
2.2 Product Overview .....	1
2.3 Design Features and Components .....	3
2.4 Typical Switchboard Layouts .....	4
2.5 Typical Customer Connections .....	5
2.6 Typical Ground Layout .....	8
2.7 Technical Information .....	10
2.8 Labels and Markings .....	10
3 Packaging and Handling .....	13
3.1 Receiving .....	13
3.2 Handling .....	13
3.2.1 Unloading from Truck .....	13
3.2.2 Unloading off Pallet .....	14
3.3 Storage .....	20
4 Installation .....	21
4.1 Pre-Installation Preparation .....	21
4.2 Anchoring .....	21
4.3 Considerations for Installation .....	23
4.4 Joining Sections .....	24
4.5 Transformer Close Coupled Connection .....	26
4.6 Electrical Connections .....	27
4.6.1 Fish Plates .....	27
4.6.2 Ground Bus Connection .....	35
4.6.3 Cable Connections .....	36
4.6.4 Busway .....	38
5 Energization .....	39
5.1 Pre-Energization .....	39
5.1.1 Pre-Energization Tests .....	39
6 Maintenance .....	41
6.1 Setting Up a Maintenance Schedule .....	41
6.2 Maintenance Inspections .....	41
7 Torque Table .....	43
8 Accessories .....	45
8.1 OHL D Installation .....	46
8.2 OHL D Operation .....	47

.....

Appendix A: Technical Support and Contacts .....	
Appendix B: Submittal Drawings .....	
Appendices	49
	49
	50



# 1 Important Safety Instructions

All information provided in this instruction manual and additional referenced documentation should be reviewed and acknowledged by all personnel responsible for the use of the equipment. All models represented in this manual are for illustrative purposes only, due to the individual specifications associated with each customer. Vertiv will not assume responsibility for actual use established by the models.

Proper installation, operation, and maintenance are critical to the performance of the equipment.

Correct operating conditions in terms of input voltage, current and the fault capacities must be ensured at the time of installing UL891 switchboard.

Refer ANSI C37.20.1 for abnormal operational conditions.

## General instructions

- Read all the instructions included in this IUG before working with the equipment.
- Store and keep this IUG to ensure proper commissioning and maintenance to ensure the prolong use of the equipment.
- Install the switchboard based on the design limitations as given in this IUG. The design limitations are presented on the main nameplate and should never be installed in applications that exceed the limits presented by the nameplate.
- Always follow standard safety protocols set forth by your company.
- Turn off all the power sources and de-energized the equipment before removing the covers and opening of doors of the equipment. All components should be locked out and tagged in line with standard protocol and ANSI Standard Z244.1 Control of Hazardous Energy – Lockout/Tagout.
- Wear PPEs while working on the switchboard.
- Only Vertiv qualified personnel should work on the Switchboard.
- If additional information is needed, please contact your Vertiv representative.

1

Important Safety  
Instructions 1 This  
page intentionally left blank

2

1 Important Safety  
Instructions



## 2 Introduction

### 2.1 General Information

Vertiv™ UL891 Switchboard range offers a fully customizable solution that improves efficiency, saves space, and enhances operator safety. The switchboard UL891 is engineered with influence from our proven IEC 60349-1 technology that has been fully tested and certified to comply with UL891 standards. The Switchboard range also includes power distribution units and remote power panels.

Features of UL891 Switchboard:

- Fully customized and design for flexibility.
- Type tested arc prevention busbar systems.
- Equipped with Type 1 gasket, and Type 3R enclosures.
- Switchboard ampacity to 6000A.
- Segregation available up to Form 4 type 7 for enhanced user safety and protection.
- Molded case circuit breaker (MCCB) UL489 and air circuit breaker (ACB) UL1066 large selection from main breaker manufacturers.
- Integration of TVSS, PQM's, Protective Relays and Controls based on site specific needs.

### 2.2 Product Overview

#### Compact

Vertiv manufactures one of the most compact switchboard designs in the North American market. UL891 Switchboard packs more power into a smaller footprint, with our flexible modular design offering a standard shallow depth of 30.2 in. This innovative design helps our customer to accommodate the demand for higher power capacity without losing valuable real estate.

#### Safe and Reliable

Built and tested with IEC influence, the design of our UL891 Switchboard is focused on achieving the highest standard of performance reliability and operator safety. Internal segregation as outlined by IEC 61439-2 reduces operator risk by limiting the propagation of internal arc fault and preserves uptime during maintenance and upgrade operations.

#### Flexible

Vertiv modular switchboard design facilitates a component agnostic solution, giving the customer more freedom to choose their preferred components from an extensive range of well known manufacturers. Designs can be customized to fit the most challenging specifications and site specific needs, while maximizing space and performance.

Figure 2.1 Typical Switchboard



Figure 2.2 Typical Power Distribution Unit (PDU)



Figure 2.3 Typical Remote Power Panel (RPP)



## 2.3 Design Features and Components

Typical switchboards are available with a variety of options. Below shows a typical arrangement with components and features for a switchboard. PDUs and RPPs use the same typical layouts, but use different components to achieve their designated goal, such as transformers and panelboards.

Figure 2.4 Rear Internal View

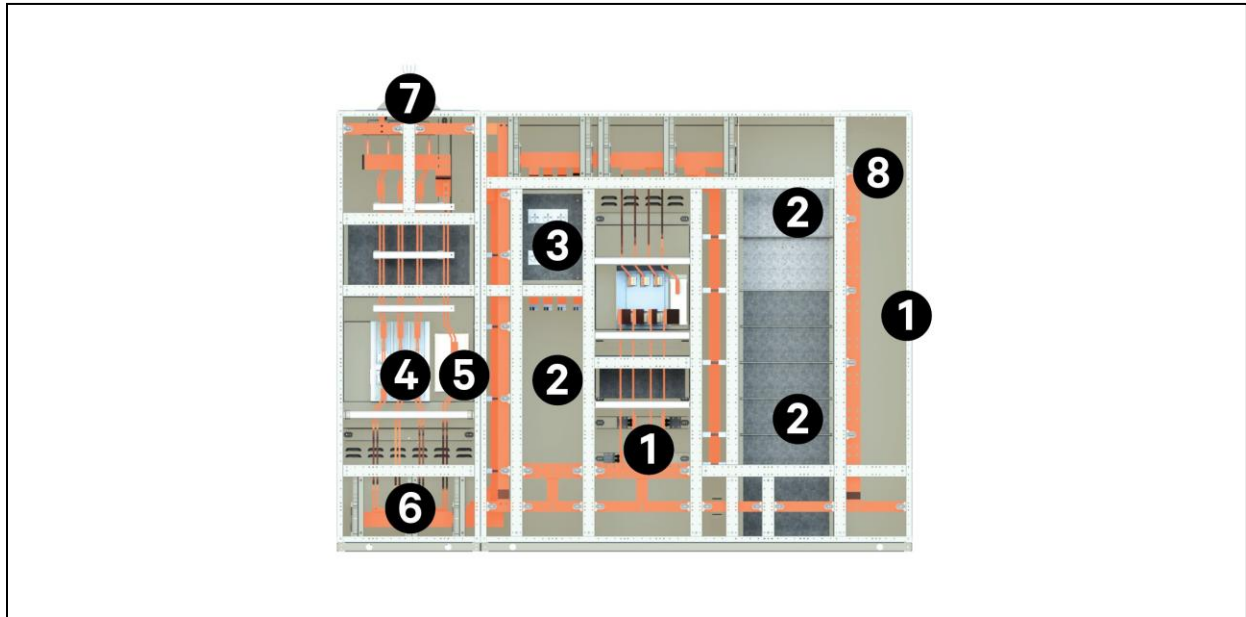
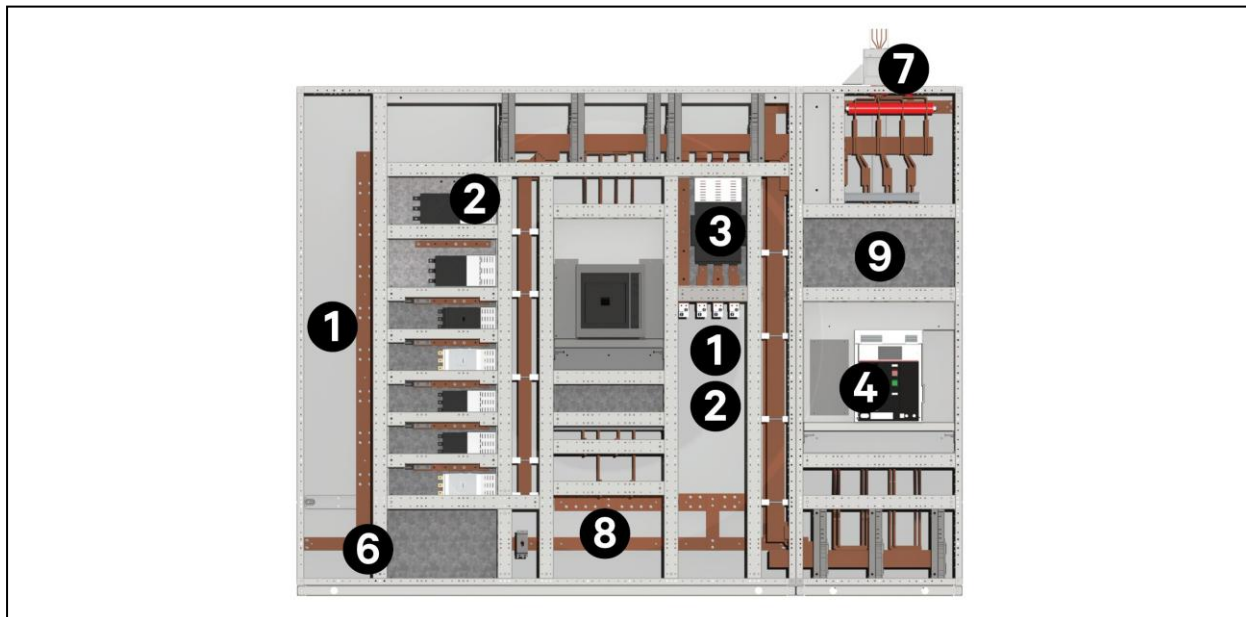

Figure 2.5 Front Internal View



Sr. No.	Item	Description
---------	------	-------------

1	Cableway Compartment	Designated for customer connections.
2	MCCB Compartment	Housing unit for MCCB.
3	MCCB – UL489 fixed mount circuit breaker	Equipment designed to break electrical circuit if tripped.
4	ACB – UL1066 draw out circuit breaker	Equipment designed to provide protection for overcurrent and short circuits using air.
5	Neutral Busbar	Voltage difference to each phase is approximately equal in magnitude and are equally spaced in phase.
6	Main Busbar	Carries the majority of the current.
7	Panel Flange Connection	Connection point between switchboard and busway route in a facility.
8	Ground Busbar	Ground network for the lineup with taps.
9	Instrument Compartment	Designated as the metering and control section.

## 2.4 Typical Switchboard Layouts

Switchboards provide typical layouts for ACBs and MCCBs within the lineup. Typical layouts include front and rear access, with single and double stack ACBs in individual sections. See Figure 2.6 below.

Standard MCCB columns with MCCBs stacked on top of each other in individual sections. See Figure 2.7 on the facing page. MCCB's use rotary handles for turning the breakers on and off. In a front access only switchboard, there is a cableway for field termination.

Figure 2.6 Typical ACB Layout



## 2.7 Typical MCCB Layout

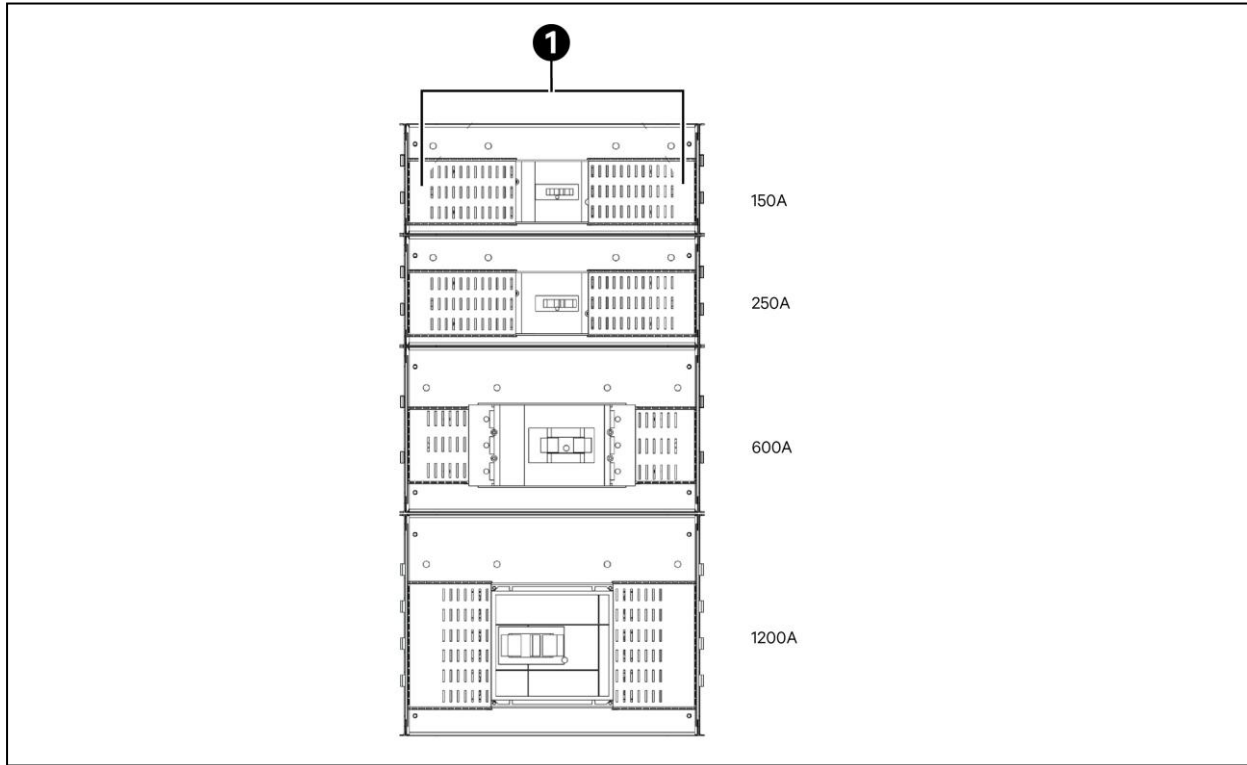

Item	Description
1	Line/Load Shrouds

## 2.5 Typical Customer Connections

Each breaker, either ACB or MCCB, has typical field termination arrangements that are used, unless specified on a per project basis. Below are the typical field terminations for the different ACBs and MCCBs amperages. Quantities of lug provisions vary per nominal breaker rating. All lug pads consist of the standard NEMA hole pattern, which is 1.75 in. x 1.75 in. with a clearance hole for 0.5 in. hardware. The 0.5 in. hardware consists of a bolt, 2 Belleville washers (one on each side of the connection), and a nut.

Below are the different typical customer connections.

Figure 2.8 Typical Provision for Front Access and Top Incoming Customer Cable Connections

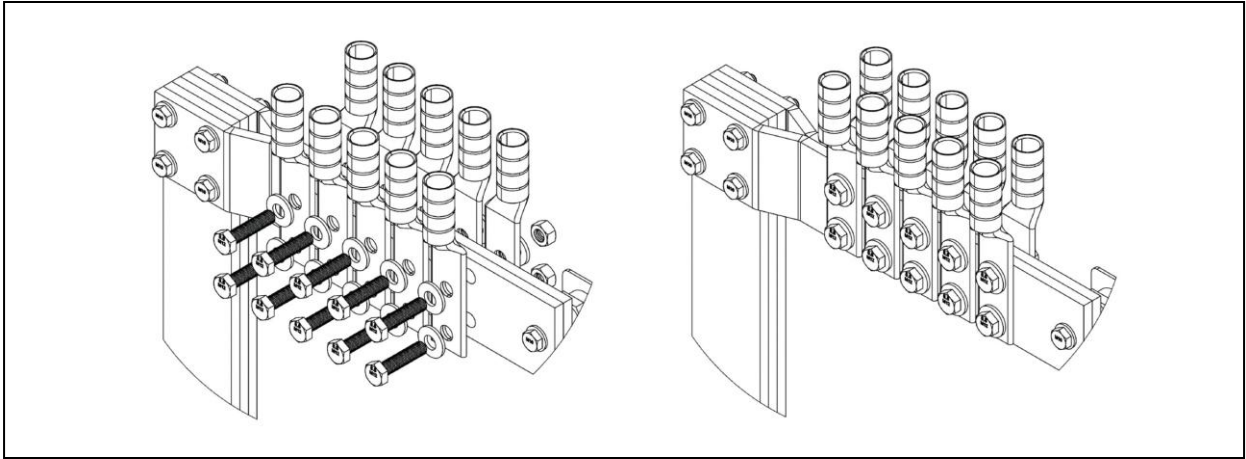

Figure 2.9 Typical Provision for Front Access and Bottom Incoming Customer Cable Connections

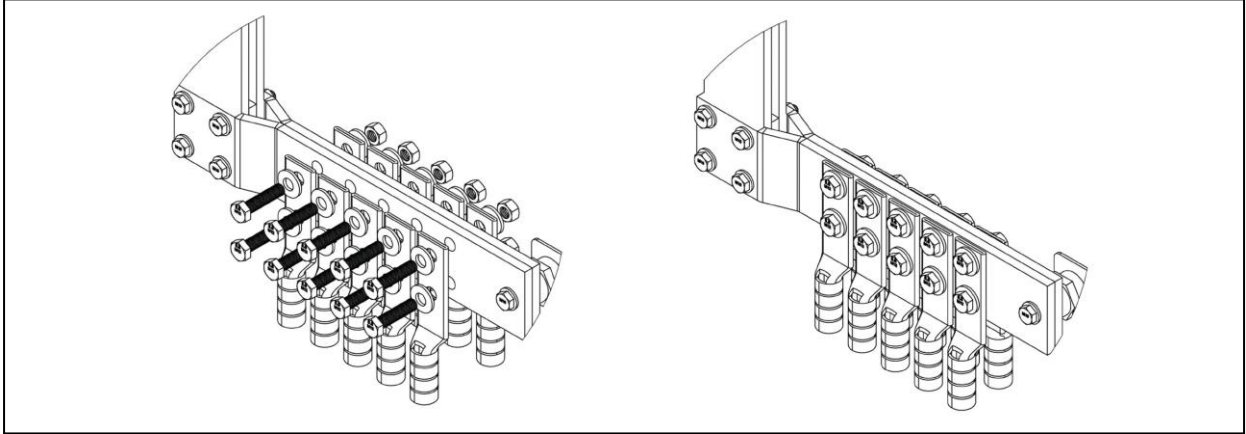
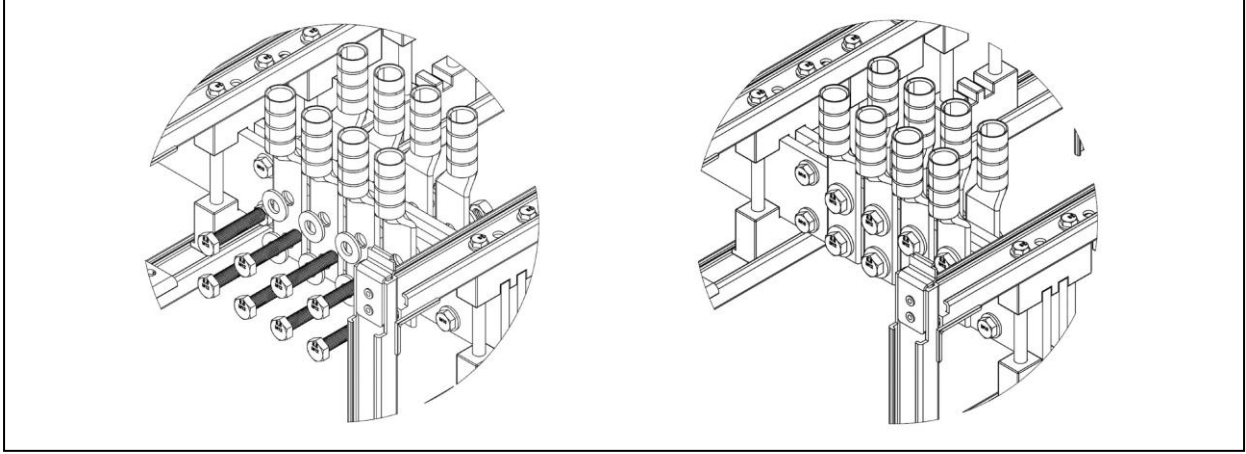

Figure 2.10 Typical Provision for Rear Access and Top Incoming Customer Cable Connections



2.11 Typical Provision for Rear Access and Bottom Incoming Customer Cable Connections

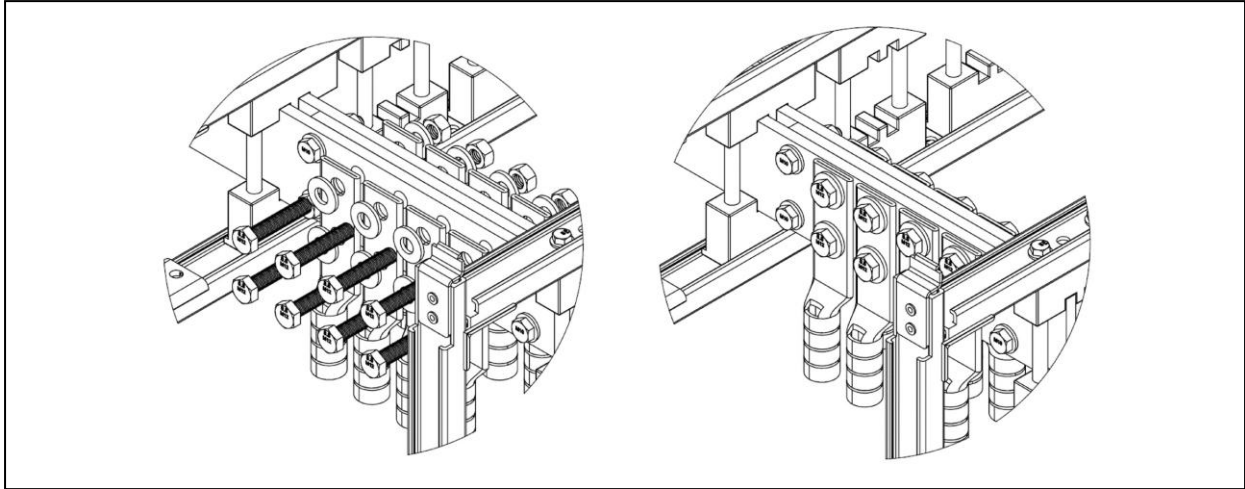
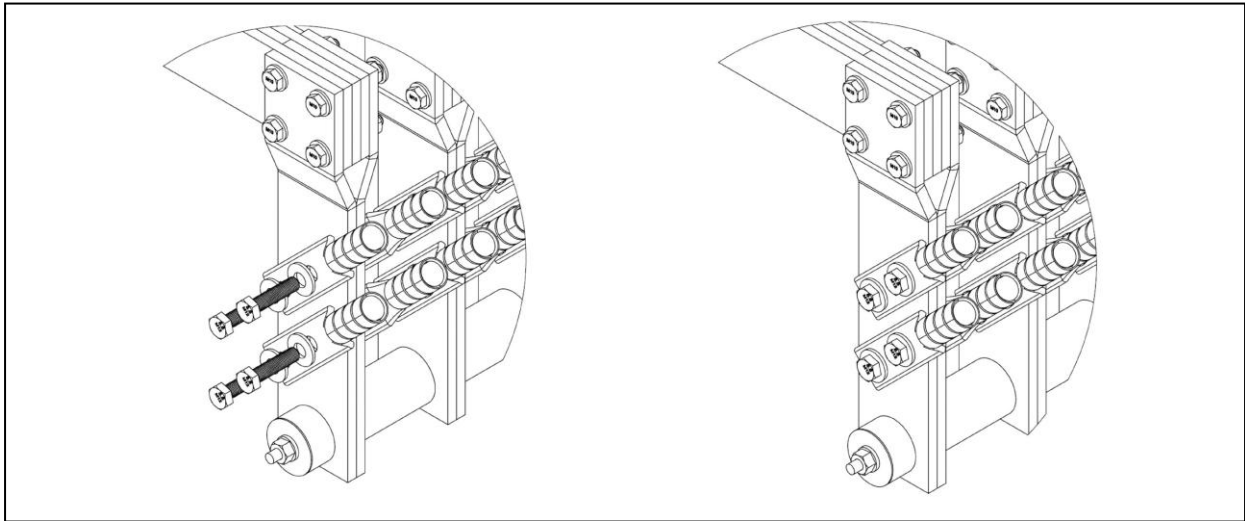

Figure 2.12 Typical Provision for Rear Access and Bottom Incoming Customer Cable Connections



### 2.13 Typical Provision for Double Stacked Front/Rear Access and Bottom Incoming Customer Cable Connections

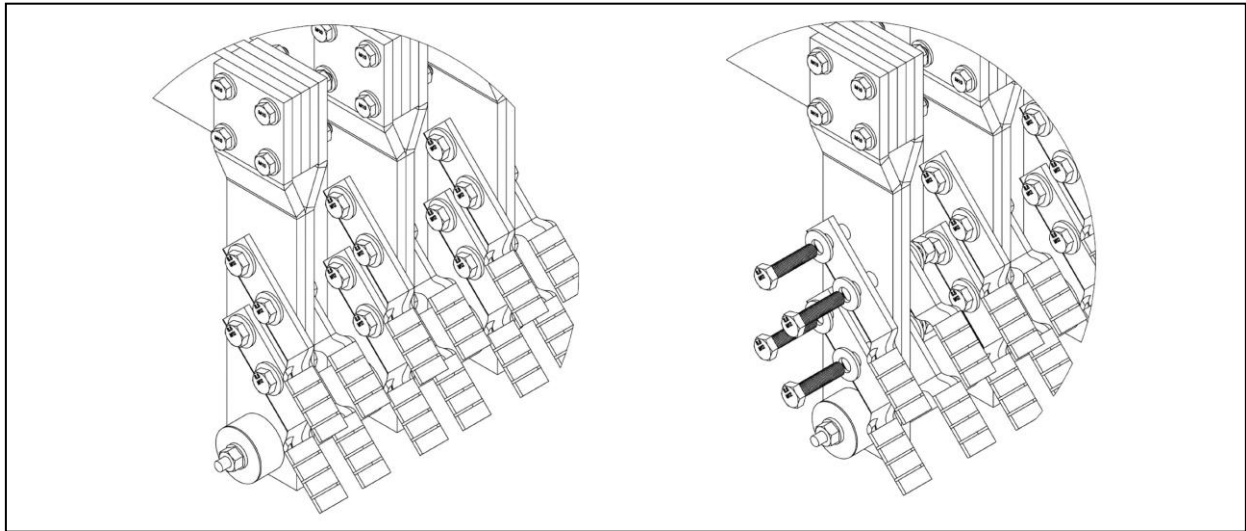
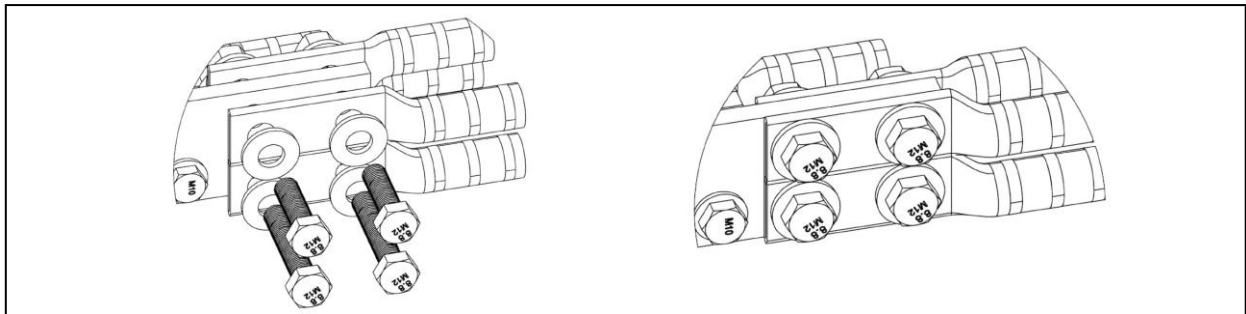

Figure 2.14 Typical Provision for MCCB Customer Cable Connections



## 2.6 Typical Ground Layout

The ground is a system that runs the complete length of any switchboard. There are taps periodically throughout each switchboard for tapping off for field terminations.

Below are typical arrangements of ground cable provisions per switchboard configuration.

Figure 2.15 Typical Ground Dropper Arrangement with Provisions for up to two (2) Compression Lugs

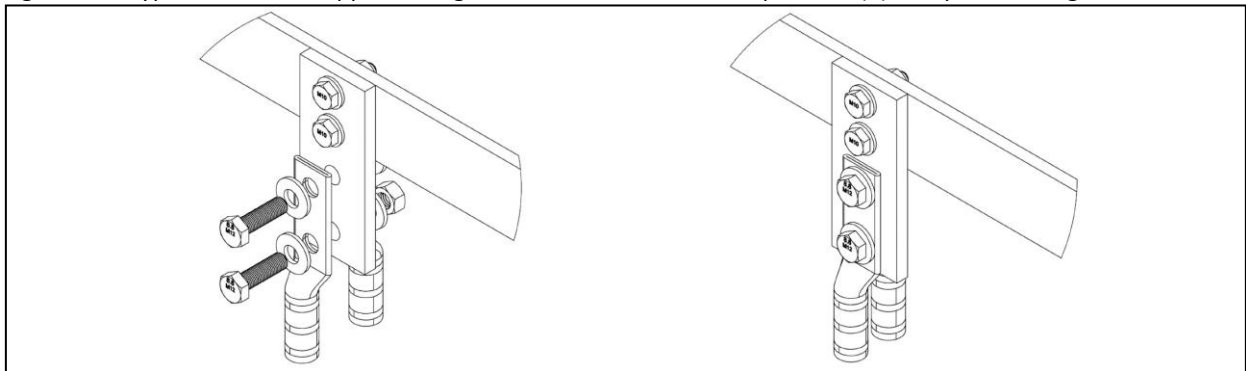

2.16 Alternate Ground Dropper Arrangement with Provisions for up to two (2) Compression Lugs

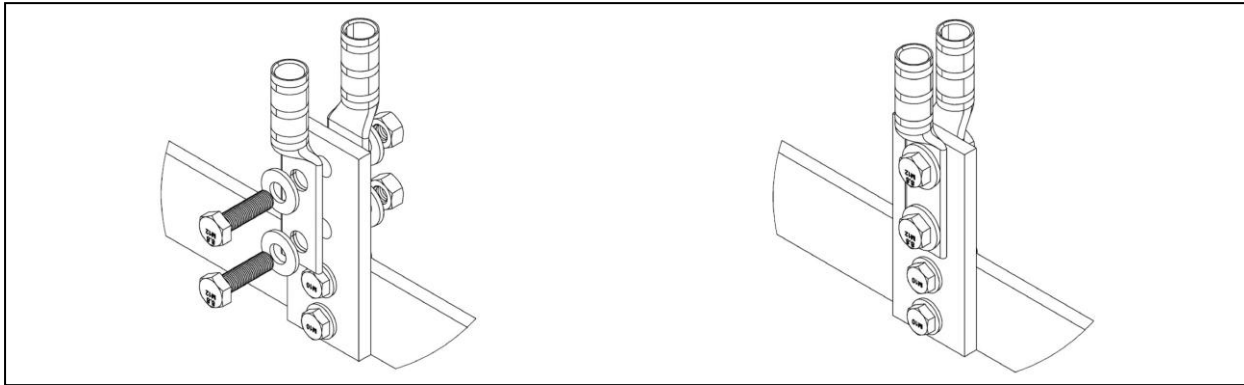

Figure 2.17 Typical Ground Dropper Arrangement with Provisions for up to four (4) Compression Lugs

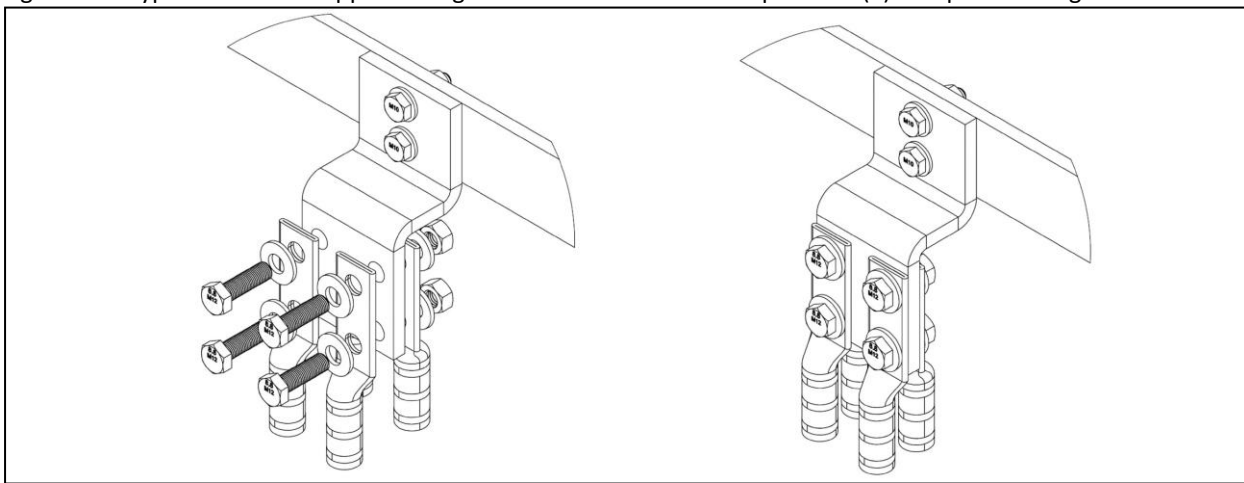
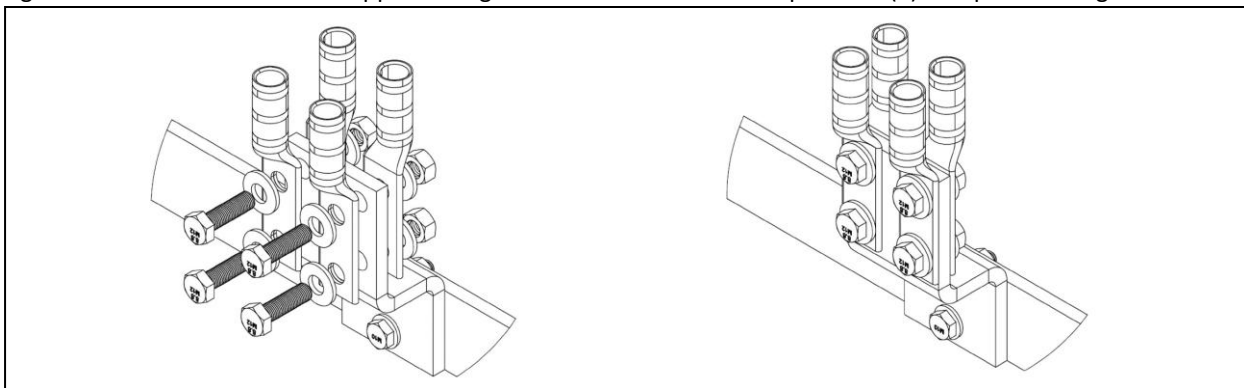

Figure 2.18 Alternate Ground Dropper Arrangement with Provisions for up to four (4) Compression Lugs



## 2.7 Technical Information

Table 2.1 Technical Information

Criteria	Description	Specification
Standard	Safety	UL891 - Standard for Safety Switchboards

	Seismic Requirement		IBC 2012 and CBC 2010
	Seismic Protection		AC156
Test Certificate		Switchboard is designed, tested, and constructed based on the standard above	ETL File: 103065685CRT
Electrical Data	Rated Voltages	Rated insulation voltage, Vi	2.2 kV
		Rated operating voltage, Ve	Up to 1000 VAC
		System types	3 phase-3 wire, 3 phase-4 wire
		Rated frequency	60 Hz
	Rated Ampacities	Rated current	Up to 6000 A
		Rated short circuit current	Up to 100 kA at 600 V and 10 kA at 1000 V
	Breakers	MCCB	UL489, multiple brands
		ACB	UL489 or UL1066, multiple brands
	Transformer	Close coupled to switchboard or internal for PDUs	
	Busway	Available for ratings 800-6000 A	
Mechanical Data	Dimensions	Height in (mm)	Up to 94.8 in. (2407 mm)
		Width in (mm)	Custom per project, no limitation
		Depth in (mm)	Up to 60.5 in. (1536 mm)
	Surface Protection	Frame	Paint finish
		Enclosure	Paint finish
	Enclosure Type	Type 1 A and Type 3 R (Front and rear access dependent on project specs)	
	Plastic Components	Self-extinguishing, flame retardant	
	Busbars	Standard - tin plated (Silver plated available)	
		Bus Bracing	Up to 100 kA at 600 V
	Paint Finish	Enclosure	Standard - RAL 7035 (Special colors are available)

## 2.8 Labels and Markings

The switchboard comes standard with a master nameplate located on the main incoming section, as well as several other labels. All nameplates and labels provide information related to the switchboard and electrical data, cautions and warnings to help the personnel of important information and safety precautions.

Examples of labels that may be found on the switchboard are shown Figure 2.19 on the facing page.

#### 2.19 Typical Labels

This page intentionally left blank

## 3 Packaging and Handling

The switchboard lineup is shipped in single sections or shipping splits. Separation of splits are deemed by the project engineer and their communication with the customer. Unless otherwise requested, the single sections or splits will be wrapped and shipped on a pallet to which they are bolted. The standard size of the pallet is the width of the section or split by the depth of the section plus twelve inches (approximately six inches in the front and rear of the switchboard when centered on the pallet). Each section is unique to the job, thus the section weights vary. For actual weights and dimensions, consult equipment shipping documentation.

### 3.1 Receiving

- Ensure all sections and splits are present when switchboard arrives on site. Notify your Vertiv representative if any anomalies are found.
- A thorough inspection should be performed to make sure no damages occurred during shipment. If damages did occur, a qualified technician needs to investigate the gear for proper diagnosis.
- If the damage is from improper handling, contact the carrier and your Vertiv representative.
- All sections are inspected and marked before they leave the facility. It will be clearly marked with what side is the front, as well as the section or split number.
- A plastic cover should be used to protect the equipment from dust, dirt, moisture, and damage until it is ready for installation. The switchboard should remain attached to the pallet until it has been moved into its final installation position.
- All packaging material should be saved until the gear is ready to be installed, especially if there is a delay in the installation, so that it can be repacked and stored safely. See [Storage](#) on page 20 if a delay occurs.

### 3.2 Handling

Most switchboard sections are top and front heavy and should be handled with caution. Before moving or lifting any section, verify that the equipment that is going to be used to handle the switchboard is within the safe limits of its capacity.

#### 3.2.1 Unloading from Truck

A forklift is the best method for unloading the switchboard.

**IMPORTANT!** Only trained personnel should drive the forklift and move the switchboard. Make sure the ground is solid and all operation and safety recommendations are followed while operating the forklift.

**NOTE:** Be aware of any floors and conditions that could affect stopping and turning. Pay attention to labeling on the packaging material. Make sure that the forklift being used is rated to work in safe limits for the weight of the switchboard split being lifted.

1. Lift the switchboard sections from the front or back side.
2. The forks must run all the way through the entire shipping length and extend past the outermost part of the wooden pallet.

3. A safety strap, belt or leash approved for the purpose of securing the section should be used. Make sure the position of the strap is adequate in providing stability to the equipment, in a location that will not damage any components.
4. Slowly lift the equipment to the minimum required height from the floor for safe relocation.

### 3.1 Forklift

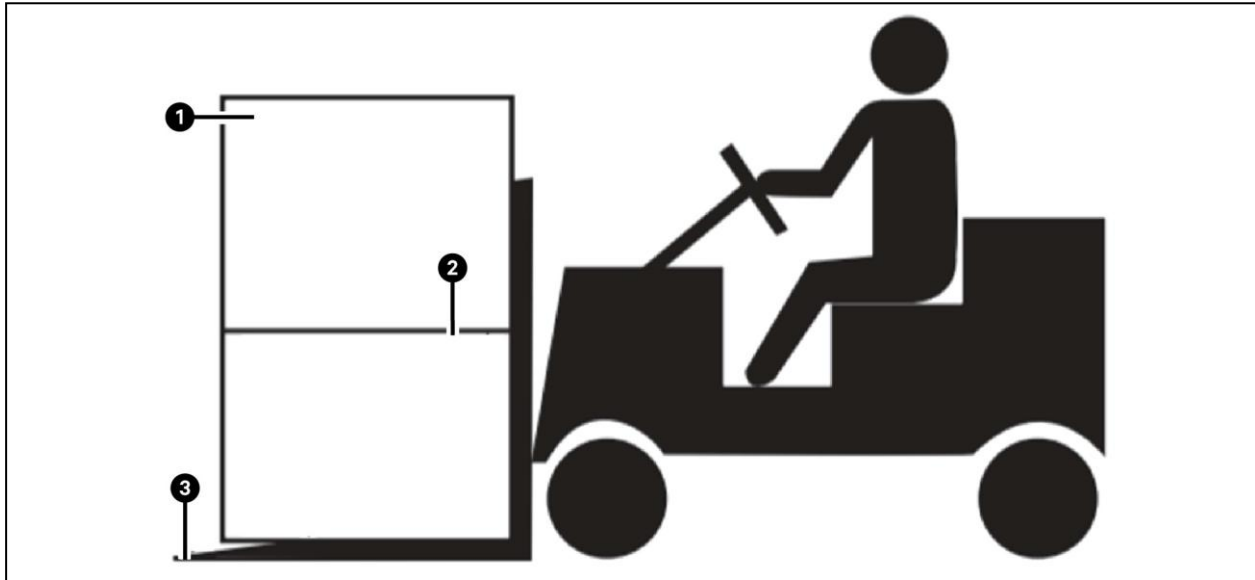

Item	Description
1	Switchboard
2	Secure switchboard to forklift with safety strap here
3	Forks under entire switchboard

### 3.2.2 Unloading off Pallet

There are a few methods for unloading the switchboard splits off the pallet and into the proper installation location. Both lifting methods are applicable for type 1A and type 3R switchboards. The recommended way is by use of lifting bars, lifting jacks, and lifting skates see section [Method 1](#) on the facing page . The other method uses lifting bars, lifting straps or chains, and a spreader with a forklift or crane see section [Method 2a](#) on page 16 and [Method 2b](#) on page 17 .

**NOTE:** Vertiv does not provide bars, jacks, skates, straps or spreaders. It is the customers responsibility to purchase or rent the correctly rated equipment needed to move the panel splits.

The switchboards also need to be unbolted from the pallet first before lifting the panel. There are holes within the plinth of each panel that allows for a steel bar to go through. The bar is used for lifting the switchboard. A bar of 2 in. (50.8 mm) diameter and 96 in. (2438.4) length should be used.

#### 3.2 Typical Lifting Bar

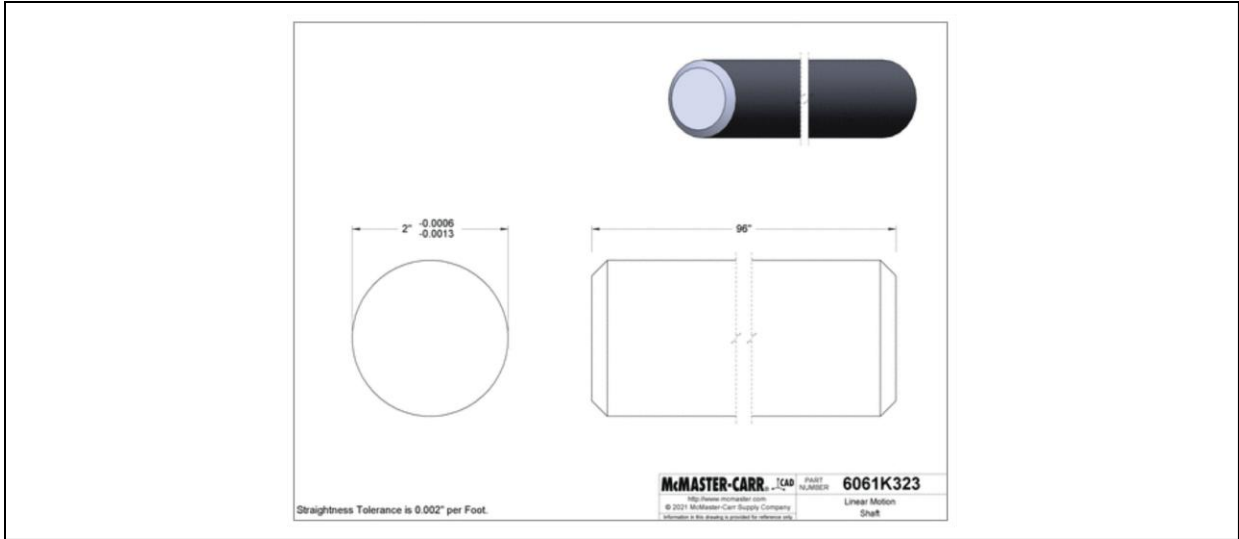

### Method 1

1. Insert the bars into the holes, use the jacks to raise the panel approximately 5 in. (127) to slide the pallet from under the panel.
2. Place 4 skates in each corner of the split and lower the jacks until the split rests on top of the skates.
3. Remove the bars and then push the panel on the skates to the designated location.
4. Re-insert the bars and raise the split using the jacks then remove the skates and lower the panel onto the ground.

### 3.3 Bars and Jacks

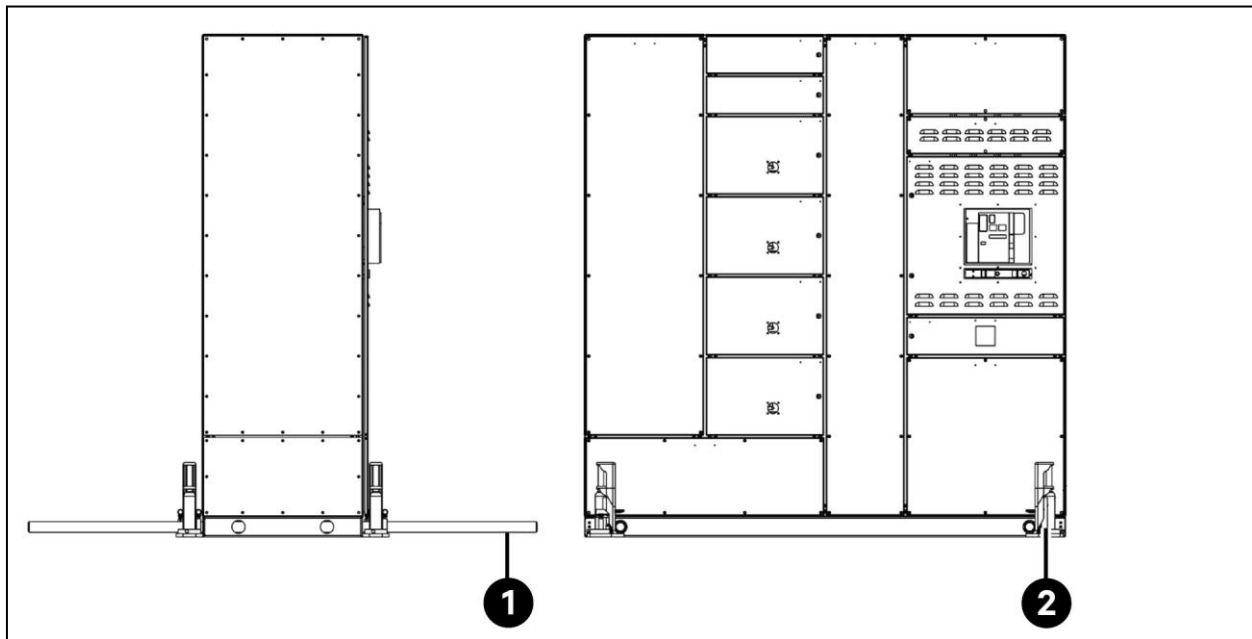

Item	Description
1	Lifting bar
2	Lifting jack

Figure 3.4 Typical Skate

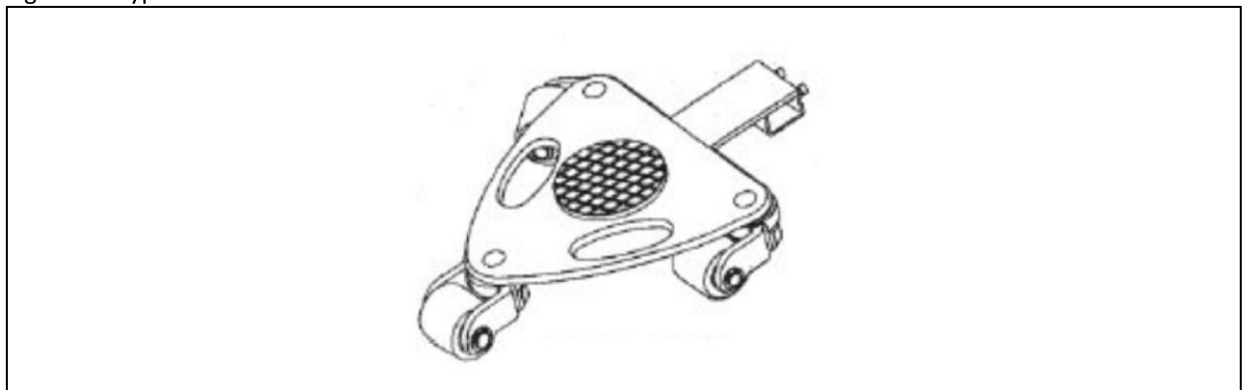

#### Method 2a

1. Insert the bars into the holes, using lifting straps around the bars with a spreader.
2. Lift the spreader using forklift and raise the panel approximately 5 in. (127) to slide the pallet.
3. Lower the panel to the minimum moving height.

4. Move the panel to the designated location by the forklift or crane.
5. Lower the panel onto the ground and detach the spreader and lifting straps, as well as the bars.

3.5 Bars, Chains, and Spreader

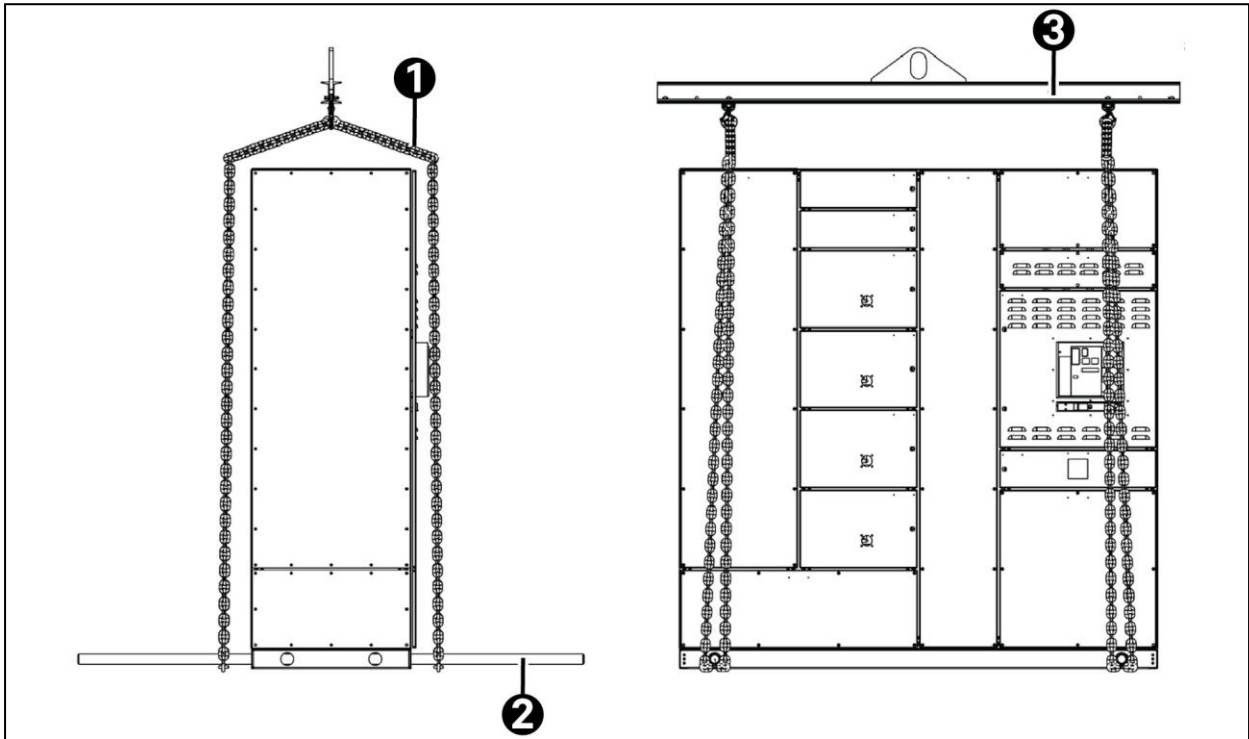

Item	Description
1	Chain or Strap
2	Lifting rod
3	Spreader bar

**Method 2b**

1. In some cases, skid plinths may be requested instead of standard plinths due to weight of the panels.
2. Use a skid plinth lifting eye for lifting. Use lifting straps to connect to the lifting eyes and spreader.
3. Use a forklift or crane to lift the spreader and raise the panel and lower the panel to the minimum moving height.
4. Move the panel to the designated location using a forklift or crane, then lower the panel onto the ground and detach the spreader and lifting straps.

3.6 Lifting Eye, Chains, and Spreader

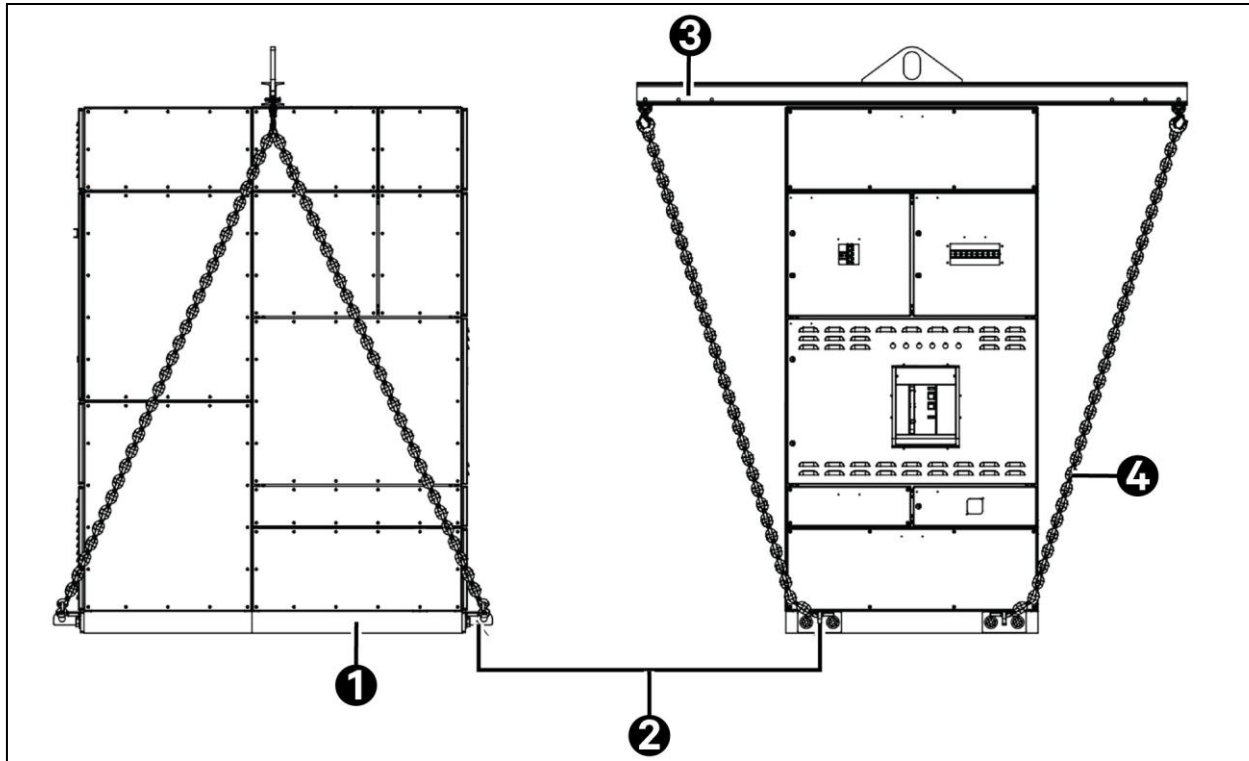

Item	Description
1	Skid plinth
2	Skid plinth lifting eye
3	Spreader bar
4	Chain or Strap

### Non traditional lifting means

1. If necessary, laid the panel on its side or back. Additional plinths will need to support and protect the switchgear structure, as well as add lifting points to the corresponding surface.
2. Mount the plinths onto the rear and/or side like the standard plinths, fitted to the base of the panel. Depending on the surface size of the side or rear, additional supports may need to be installed.
3. Remove the skins from either the rear or side to install the plinths. Mount the plinths into the frame using M8 hardware as noted on the drawings. Hardware should be torqued based on Table 7.1 on page 43.
4. Once the plinths are installed, then panel movements can be completed by a qualified movement team based on specific project MOP.
5. When the panel is in the designated location remove the additional plinths and put back the skin in place.

Item	Description
1	M8x16 socket head to mount plinth end to frame

2	Plinth end to install
---	-----------------------

### 3.7 Removing the Covers

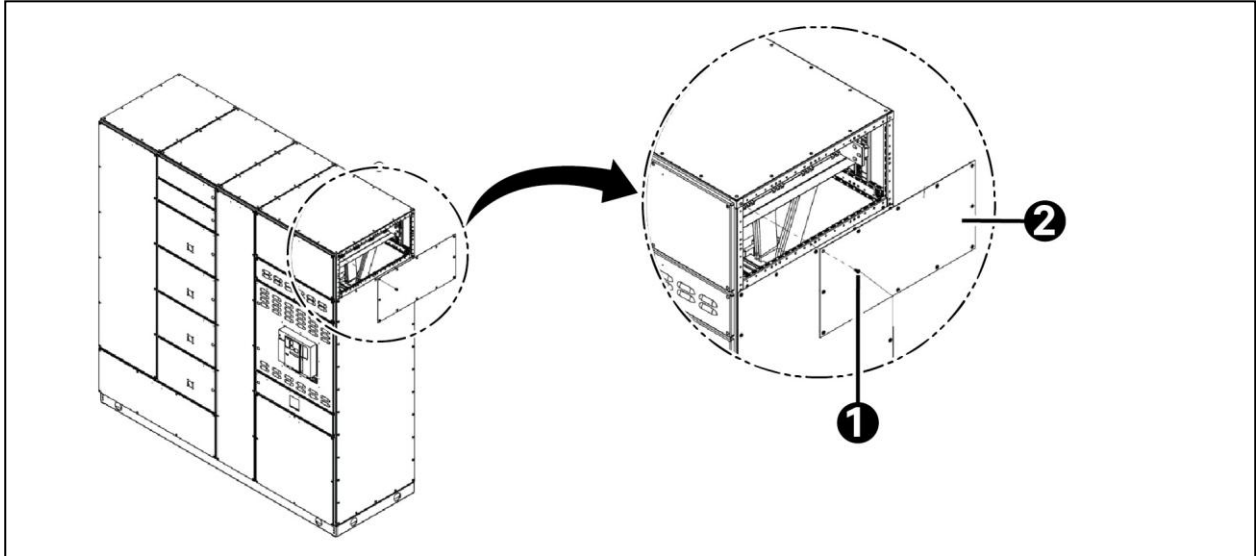

Item	Description
1	M8x12 low profile
2	Skin to be removed

Figure 3.8 Installing the Plinth End

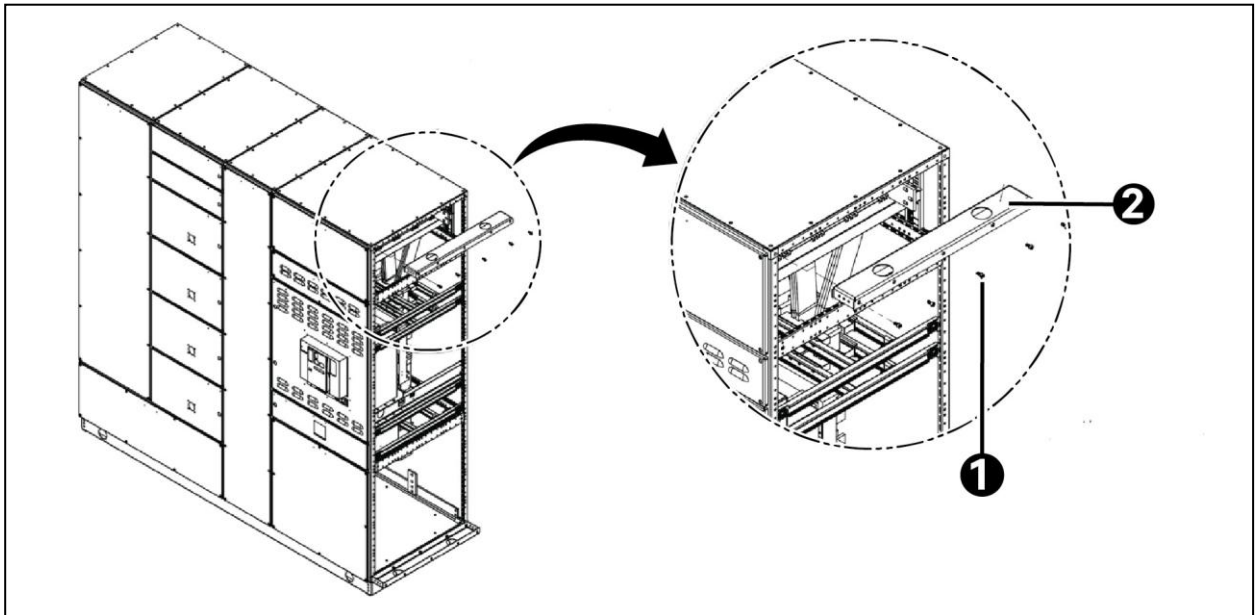

3.9 Installing the Plinth Lift-off

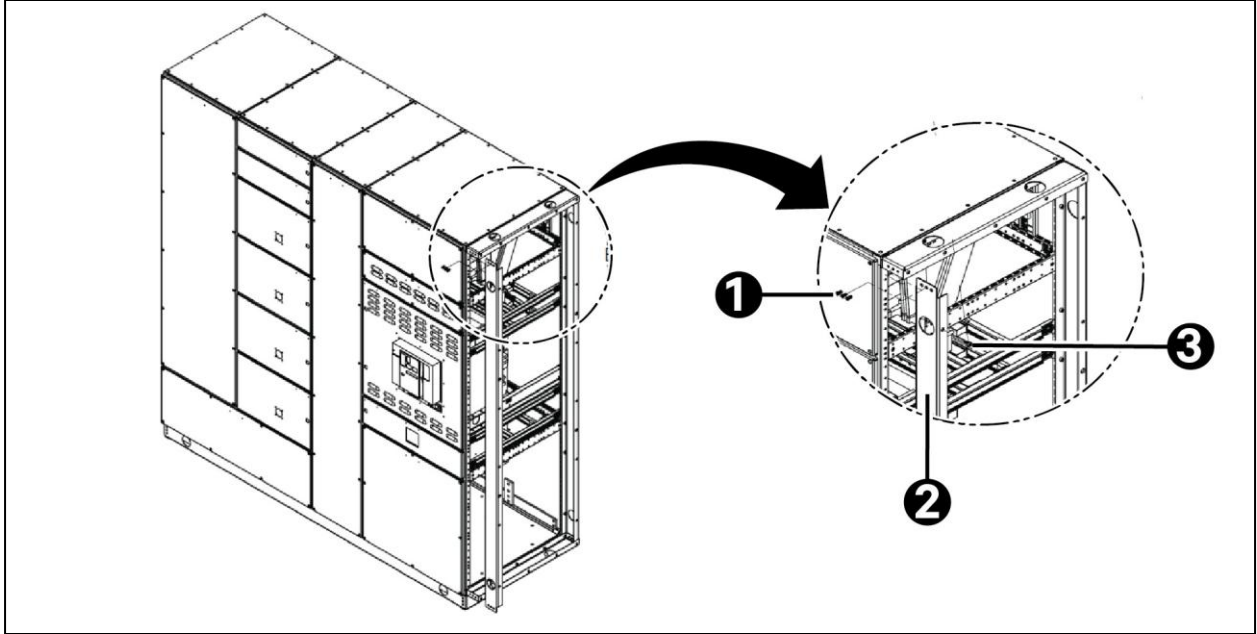

Item	Description
1	M8x12 low profile to mount plinth lift off to plinth end
2	Plinth lift off to install
3	M8x16 socket head to mount plinth lift off to frame

### 3.3 Storage

If delays occur in the installation of the switchboard then:

- It should be properly stored to avoid any type of damage.
- It should be unpacked and examined. See [Receiving](#) on page 13 .
- It should be stored in a location that has less than 50 percent humidity and a stable temperature between 32 °F to 104 °F (0 °C to 40 °C).
- Space heaters should be temporarily disconnected from internal connections and powered externally to reduce condensation.
- If the unit is going to be stored for an extended period, the sections and splits should be re-covered in the packaging material or plastic cover to help protect them.

## 4 Installation

Following are the details for the installation of the switchboards.

## 4.1 Pre-Installation Preparation

- Install the Switchboards on a smooth, solid, and level foundation (no more than  $\pm 0.125$  in. (3.175 mm) per 3 ft. (914.4 mm)).
- Prior to shipment, the complete switchboard is assembled at the factory to ensure proper alignment and connection.
- An uneven floor can cause issues with installation, with consequences of misaligned sections, units, doors, and other parts.
- Determine the layout of the switchboard.
- Verify that the available equipment space and location follow the minimum working space clearances according to the NEC standards.

For rear access switchboard , installation dimensions are mentioned below :

- Minimum of 2.5 ft (750 mm) from the highest part of the section to the ceiling.
- Minimum of 3.5 ft (1066 mm) between the front and rear of the lineup and the closest obstruction.

For front access switchboard , installation dimension are mentioned below:

- Minimum of 2.5 ft (750 mm) from the highest part of the section to the ceiling.
- Minimum of 3.5 ft (1066 mm) between the front of the lineup and the closest obstruction.
- Minimum of 4 in. (102 mm) between the rear of the lineup and the closest obstruction.

Pre-Site Visit / Site Readiness Checklist - Installing Contractor (CS-980000-00) provides further guidance to the installation team for a successful switchboard installation.

**NOTE:** Refer to the manufacturer's switchboard drawings for the glanding area for conduits. Install the Conduits in the glanding area to ensure compliance with NEC and UL Wire bending requirements.

## 4.2 Anchoring

Anchoring of each switchboard and their respective splits are different for each job. Standard practice is to bolt each split to the floor with at least four (4) M10x25 mm hex head bolts. Each split will have four (4) to eight (8) different locations that can be used for anchoring however, it is recommended to use the two (2) front and two (2) rear locations.

Access is provided to each anchoring location using the large lifting holes in each plinth. After anchoring is complete install supplied plinth caps. Refer to manufacturer drawings for exact location of anchoring holes for your specific panel.

Figure 4.1 Anchoring Detail



Figure 4.2 Typical Anchoring Locations from Edge of Plinth

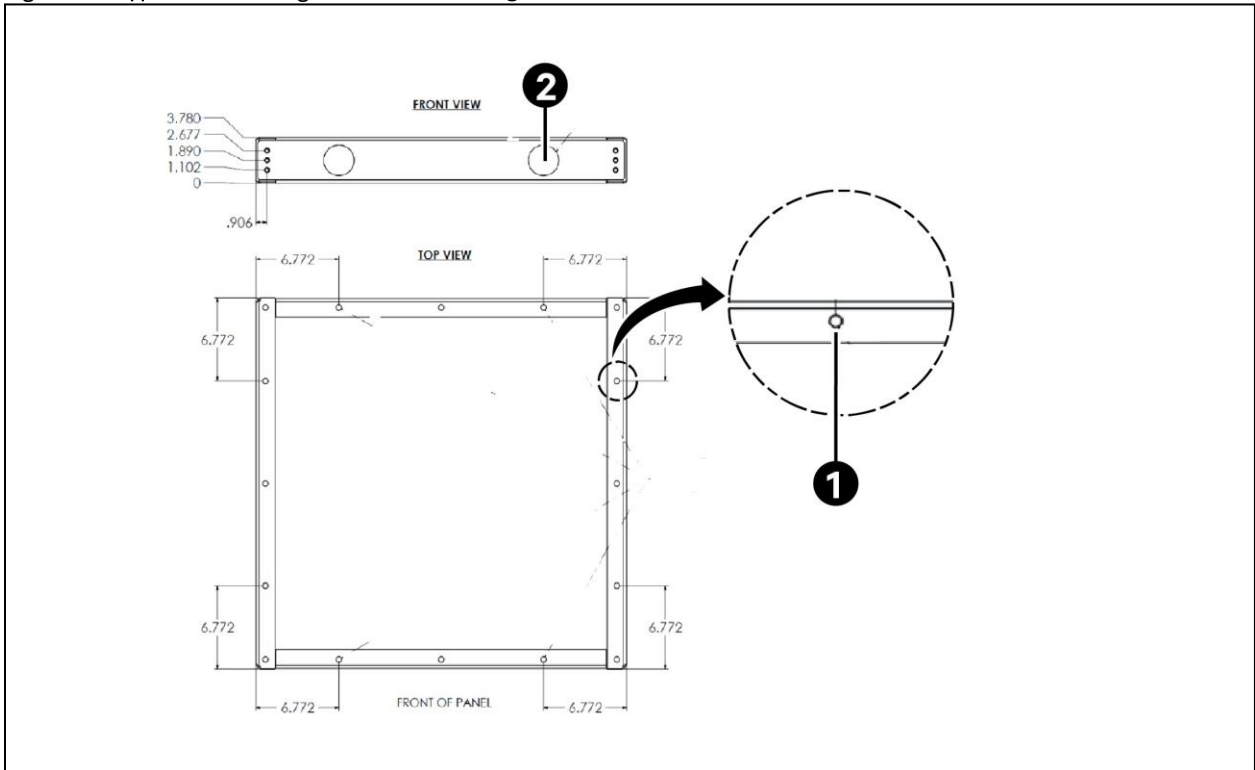

Item	Description
1	Anchoring Holes 0.453
2	Plinth access to anchorage point

### 4.3 Considerations for Installation

Use methods described in [Unloading off Pallet](#) on page 14 to move the switchboard into its final position. Use extreme caution and appropriate practices and equipment when doing so. Note that most switchboards will be heavy from top and front. Switchboards are shipped as a whole or in individual sections that are joined together. Determine the orientation of the switchboard or of each split by the manufacturer drawings and markings on the units. A drawing will provide the splits in order and where they will join. Each section will have a label that states 'SECTION # OF #' (see Figure 4.3 below). These labels are in either a control or breaker section closest to eye level of an average human.

Figure 4.3 Label Illustration

Most switchboard sections are designed to be front aligned, manufacturer drawings provided will show footprint details. The orientation on the drawings must be maintained as specified (see Figure 4.4 below).

Figure 4.4 Front Aligned Switchboard

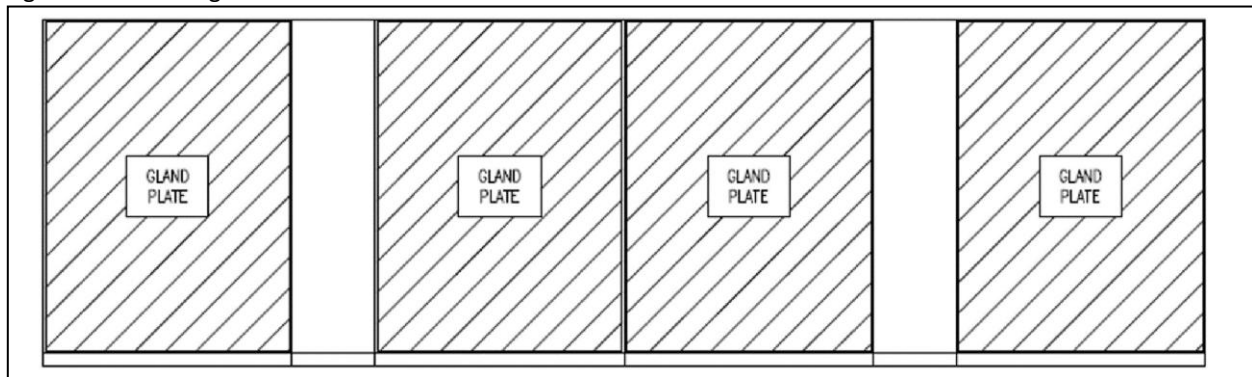

Sections of the switchboard may contain factory bus and/or cabling to connect power between splits and other components. Installers should note location and orientation of all splice plates and/or cables to be installed once sections are joined and in place. All splice plates and hardware will be provided to complete these connections. These items will be contained in a box, either in one of the splits or on a pallet by themselves. Keep all bus and hardware in a clean and protected environment to guard against damage until they are installed. Make sure to keep factory installed component cables protected from potential damage when moving sections into place.

Outdoor switchboard sections will ship with uninstalled roof caps for each split along the panel. Make sure these roof caps and associated hardware are kept in a clean and protected environment to protect against potential

damage. Once the split is/are in their permanent location, then install the roof cap. Where two or more type 1A or type 3R switchboard sections come together, they should first be aligned, then all sections leveled. Once aligned and leveled, join the switchboard sections together.

## 4.4 Joining Sections

Hardware for joining the switchboards is provided by the manufacturer. The standard hardware provided is an M8x12 mm socket head screw. There will be a total of 27 to 30 installed per split, depending on the depth of the panel. A cluster of holes are provided on the frame of each switchboard section for this purpose (see Figure 4.5 below). The holes are located every 7.6 in. (193.04 mm) in the front, top, and rear of each section. A minimum of 7 to 8 locations will need the joining screws to pull the sections together. Figure 4.6 on the facing page shows the typical locations for joining the splits together.

While maintaining the level and alignment of the structures, apply torque of 10 Nm (7 ft-lbs.). If the switchboard is outdoor, make sure the cap is also installed at each split, as well as the front joining hardware (See Figure 4.7 on page 26). Hardware for the cap and front joining should be torqued to the values set forth in Table 7.1 on page 43. Once the switchboard sections are attached, visually inspect, and verify the boards are free of any foreign objects, and that necessary clearances for live parts are still maintained.

Figure 4.5 Typical Frame Joining

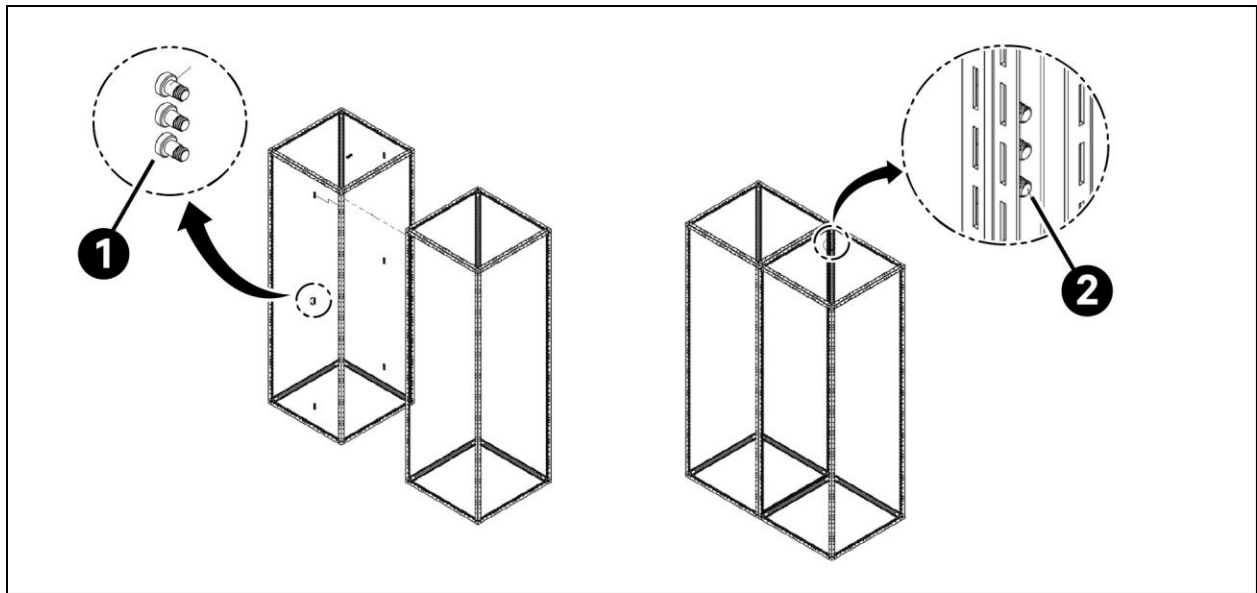

Item	Description
1	Joining Screw
2	Joining screw threads into both frame

4.6 Joining Locations  
 Typical Front Access Joining Location

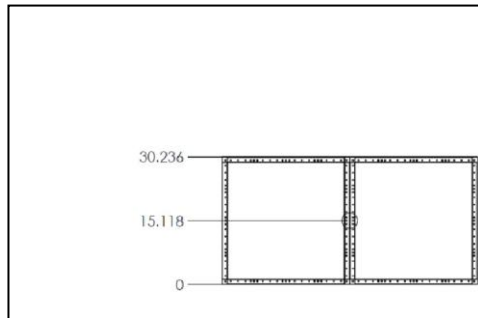

Top

Typical Rear Access Joining Location

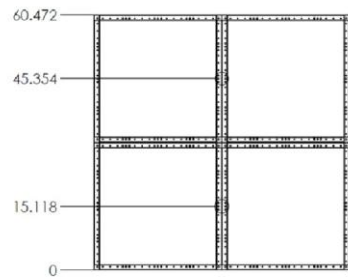

Top

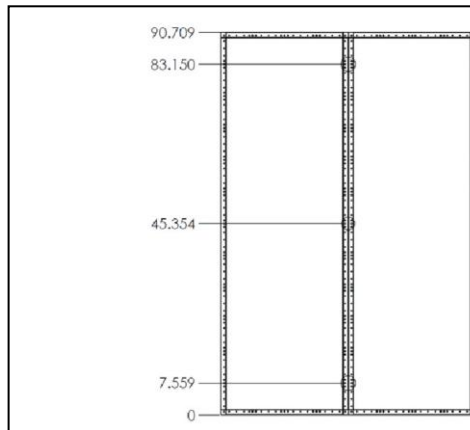

Front/Rear

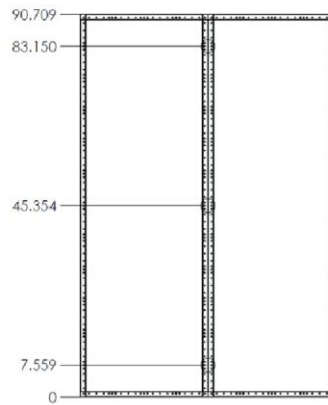

Front/Rear

NOTE: Location identified and above are the typical cluster of holes for joining. The exact location above are not required, but should be three (3) separate cluster of joining screw up the height of the front and rear. Only one (1) cluster of joining screw on top for anything less than 30.236 in. (768.096 mm) two (2) set for anything over 30.236 in. (768.096 mm).

4.7 Joining Locations

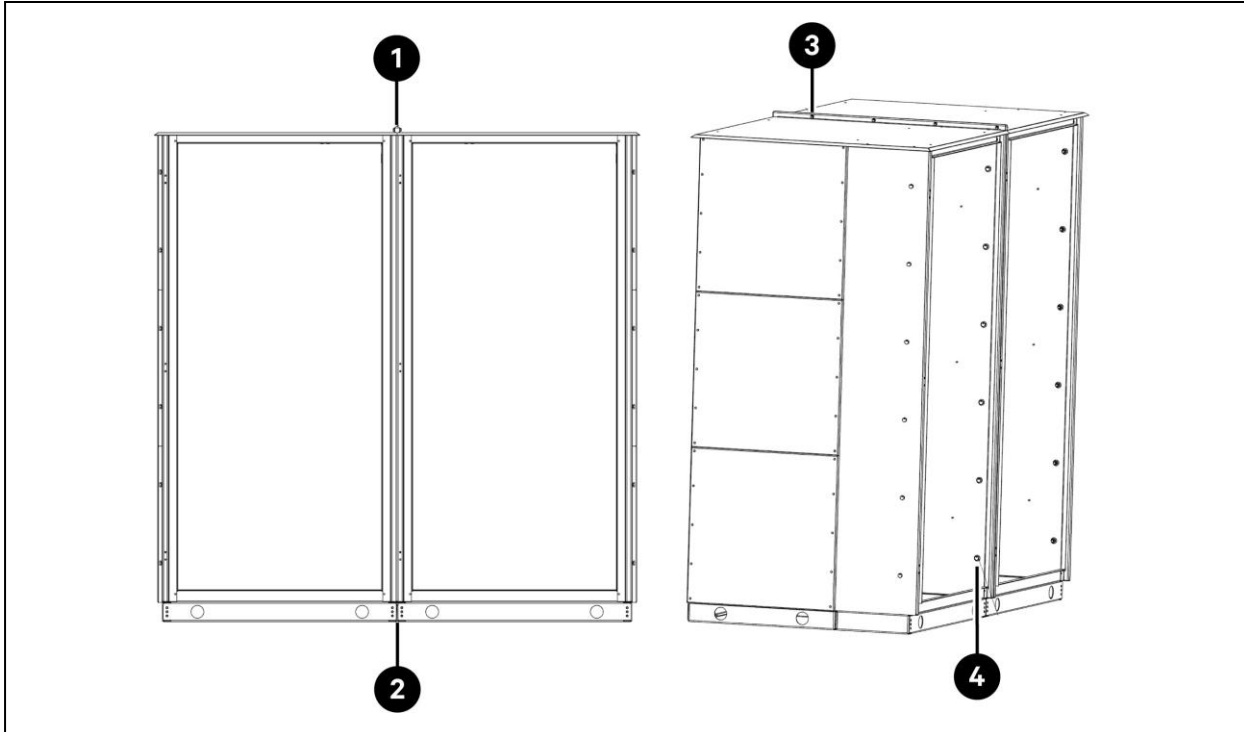

Item	Description
1	Cap
2	Joining spilt
3	M8 with gasketed washer
4	M12 bolt with washer and nut

## 4.5 Transformer Close Coupled Connection

Close coupled transformer connections are another means of joining, but it involves joining the switchboard to a transformer enclosure. This is typically done with a throat supplied on the switchboard that would mount to the side of the transformer's enclosure (see Figure 4.8 on the facing page). The copper from the switchboard and the

transformer are typically connected via flexibar or braided copper rated for the application. Both normally connect using 0.5 in. or M12 hardware.

#### 4.8 XFMR

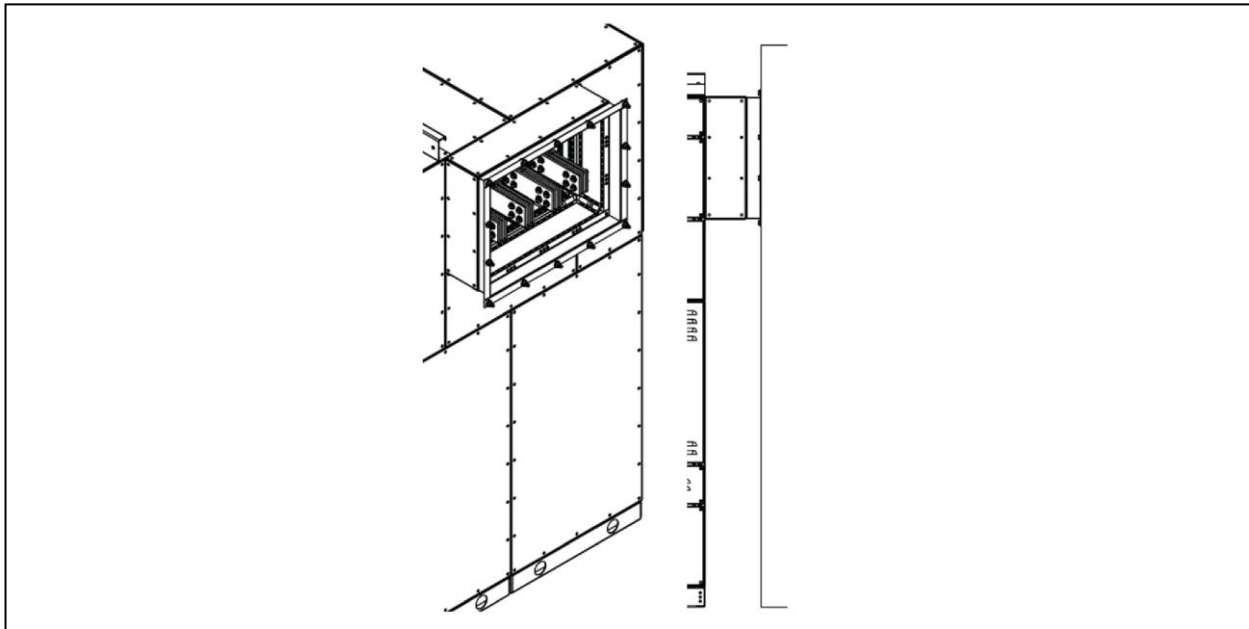

## 4.6 Electrical Connections

Several methods may be used to make electrical connections within switchboard splits. One or all methods may be used in a section and/or a switchboard lineup. These include bus splice plates, field terminal cabling, and busway connections. Examine the manufacturer's drawings for details pertaining to each switchboard section. Remove covers and side sheets as needed to access switchboard connection points. Retain all covers and mounting hardware for reassembly. Protect hardware and parts from moisture, debris, and other potential causes for damage.

### 4.6.1 Fish Plates

Fish plates are pieces of bus bar that adjoin the main horizontal and/or vertical bus that runs between different sections of the switchboard. Depending on the configuration and alignment of the switchboard, multiple fish plate configurations can be used. The different types of splice plates and connections are identified below based on

amperage. Various amperages can be configured with either two or three bus laminations per phase, identified in parenthesis along with each amperage below. Apply torque settings for M10 hardware as set forth in Table 7.1 on page 43.

4.9

Connection

800A (2X30X10)

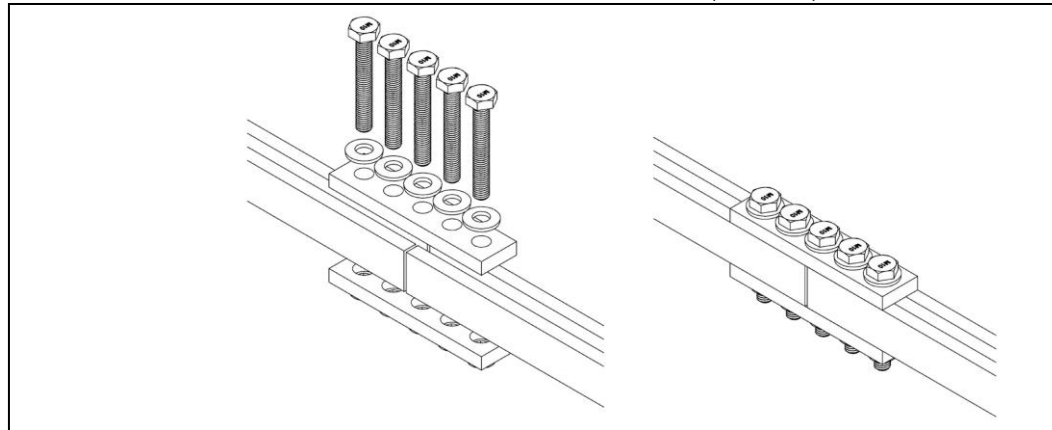

Figure 4.10 Straight Bus Connection – Traditional Fish Plates 1200A (2X40X10)

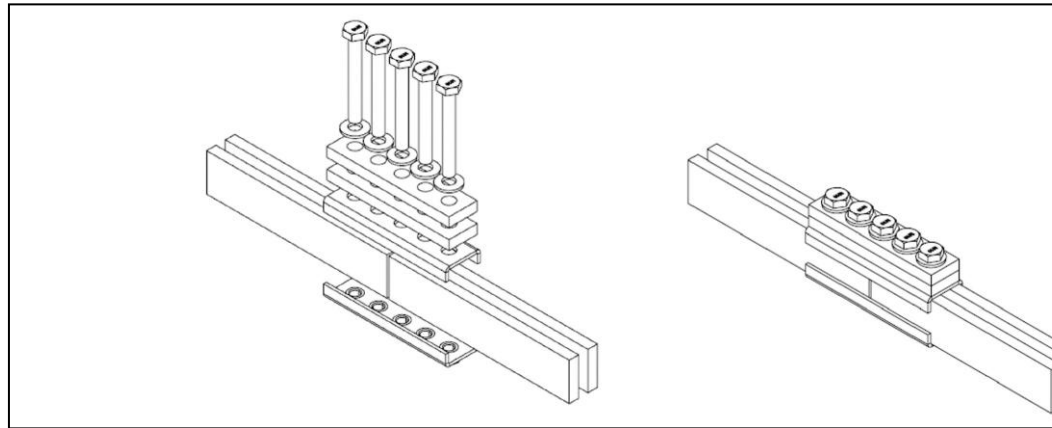
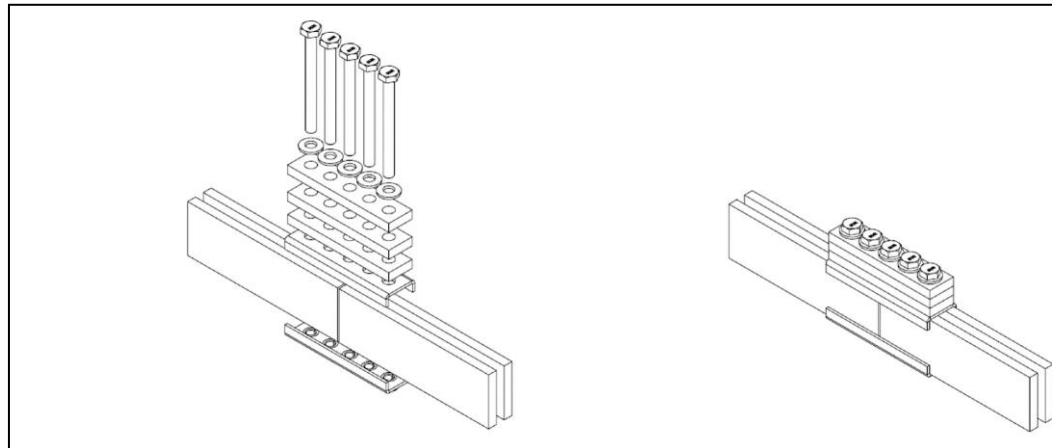

Figure 4.11 Straight Bus Connection – Traditional Fish Plates 1600A (2X60X10)



4.12

2000A (2X80X10)

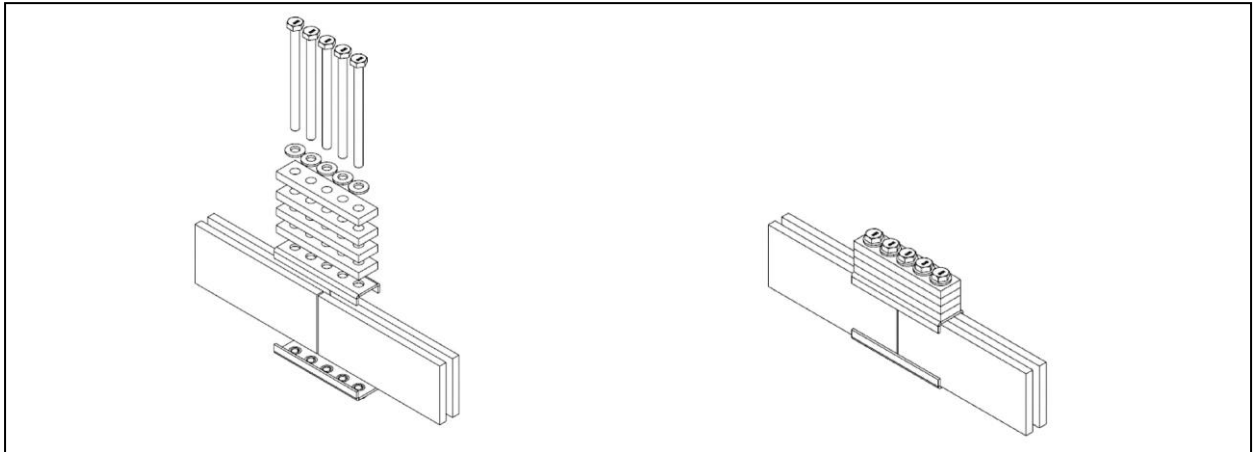

Figure 4.13 Straight Bus Connection – Traditional Fish Plates 2500A (2X100X10)

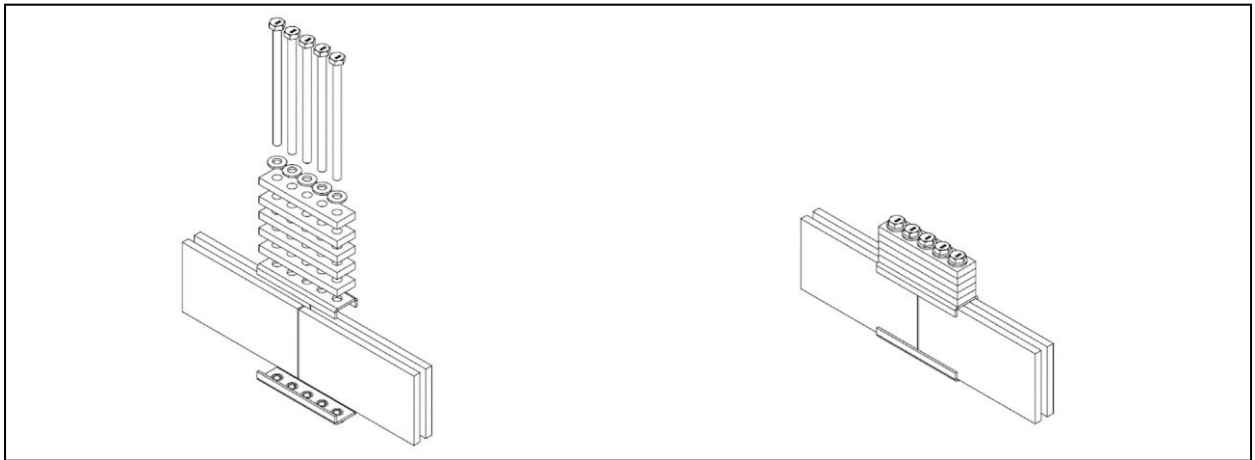
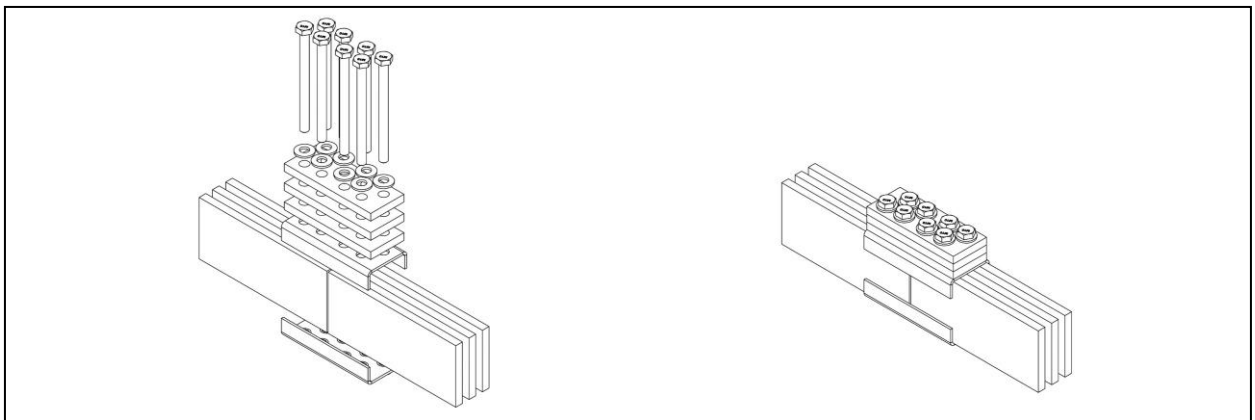

Figure 4.14 Straight Bus Connection – Traditional Fish Plates 2500A (3X80X10)



4.15

3000A (2X100X10)

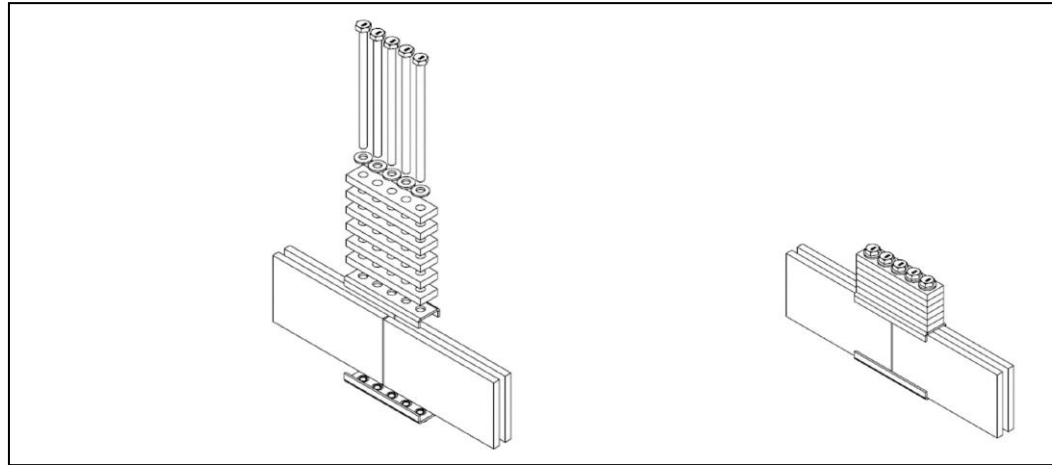

Figure 4.16 Straight Bus Connection – Traditional Fish Plates 3000A (3X80X10)

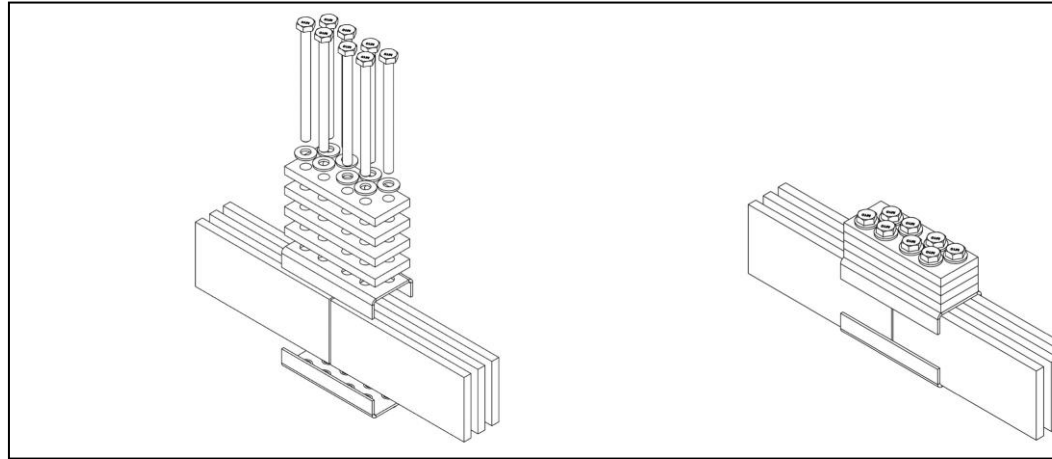
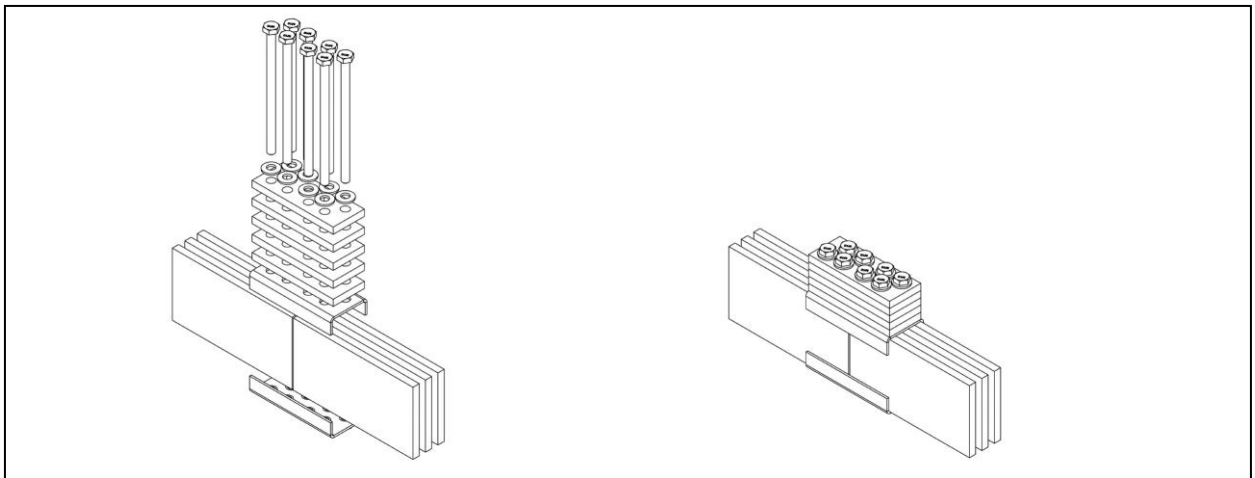

Figure 4.17 Straight Bus Connection – Traditional Fish Plates 4000A (3X100X10)



4.18

Splice Fish Plates 2000A (2X80X10)

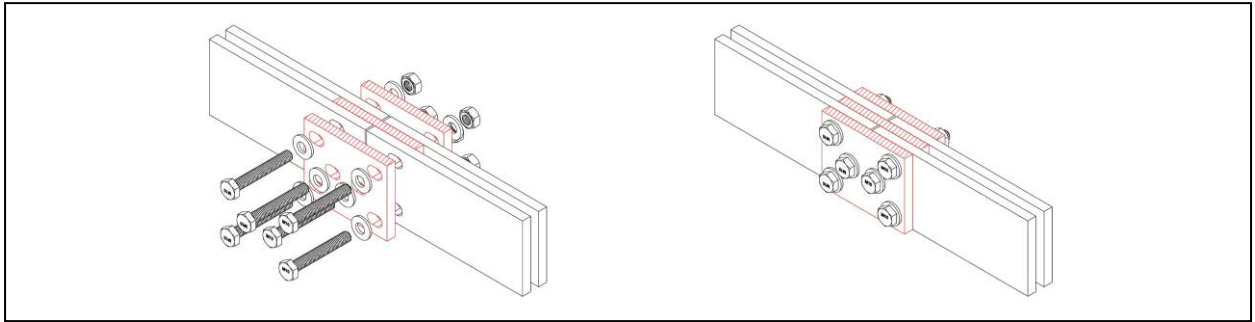

Figure 4.19 Straight Bus Connection – Splice Fish Plates 2500A-3000A (2X100X10)

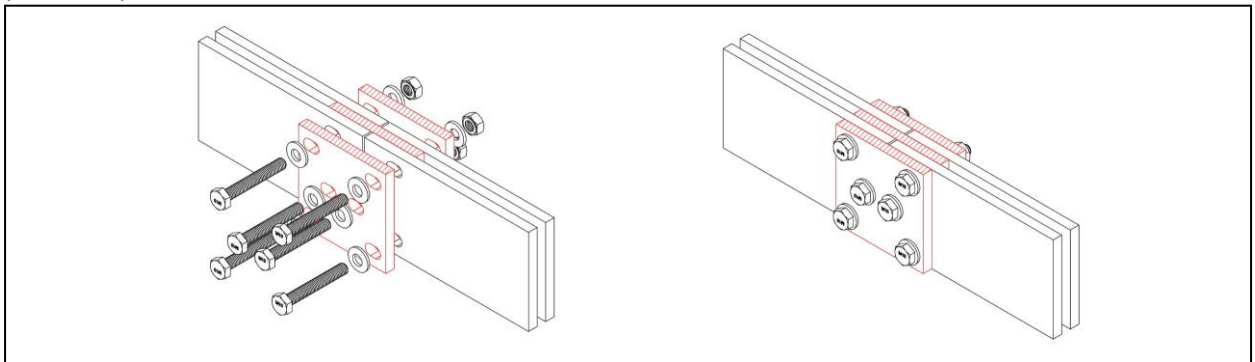
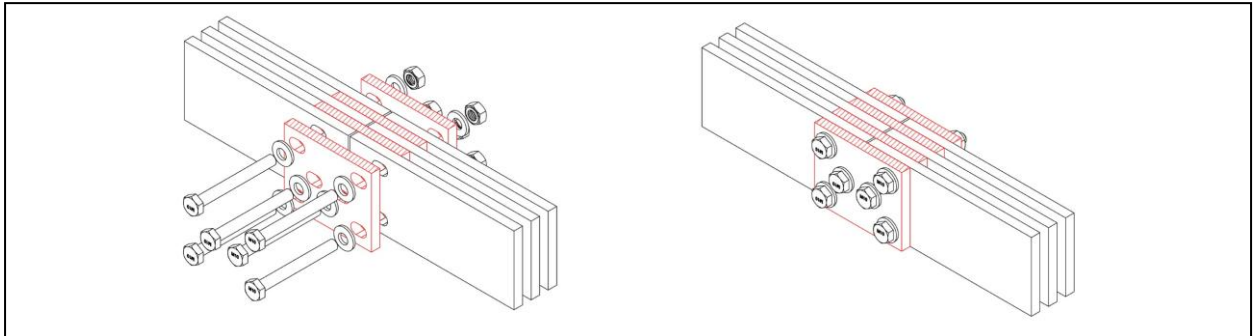

Figure 4.20 Straight Bus Connection – Splice Fish Plates 2500A-3200A (3X80X10)



4.21

Splice Fish Plates 4000A (3X100X10)

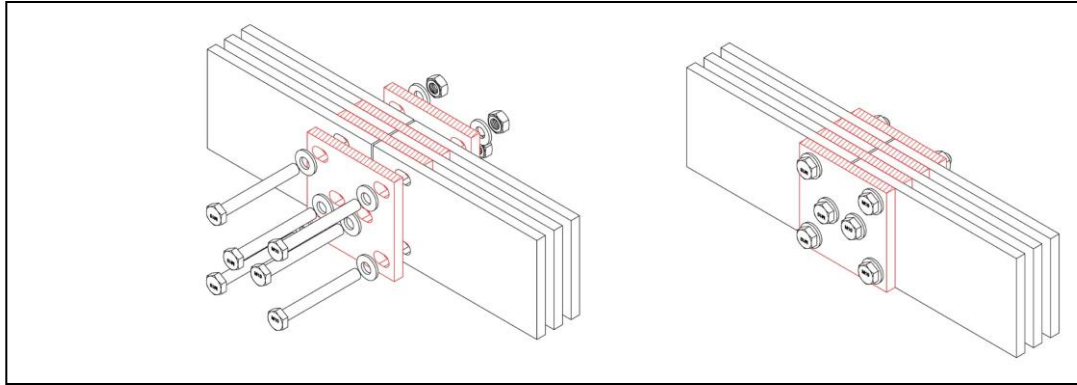

Figure 4.22 Transition Bus Connection – Traditional Fish Plates 800A (2X30X10)

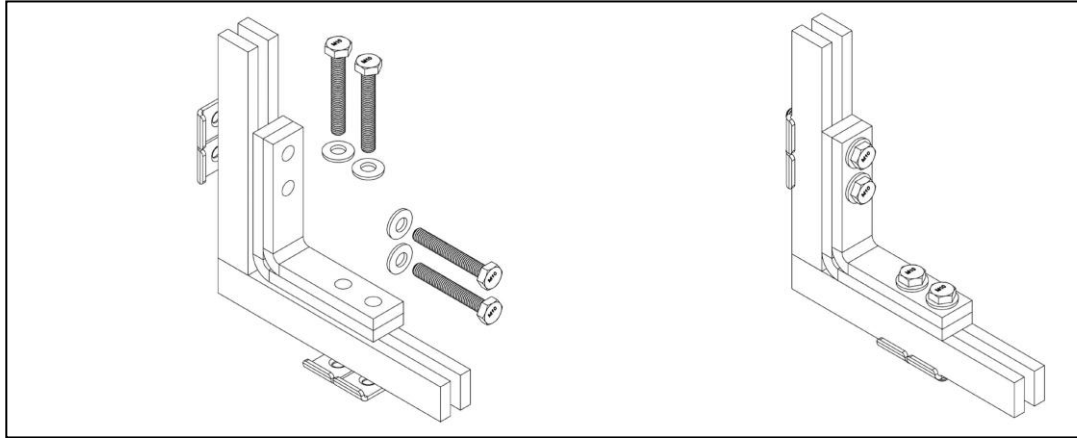
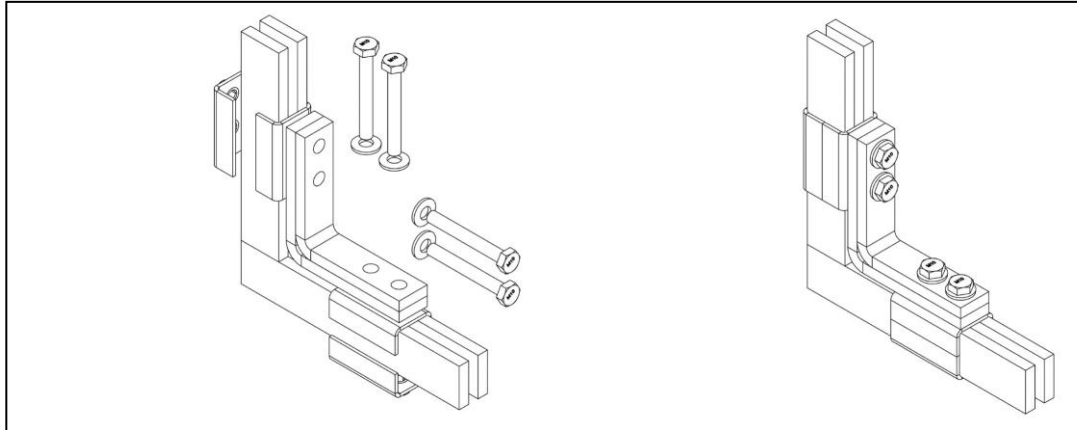

Figure 4.23 Transition Bus Connection – Traditional Fish Plates 1200A (2X40X10)



4.24

1600A (2X60X10)

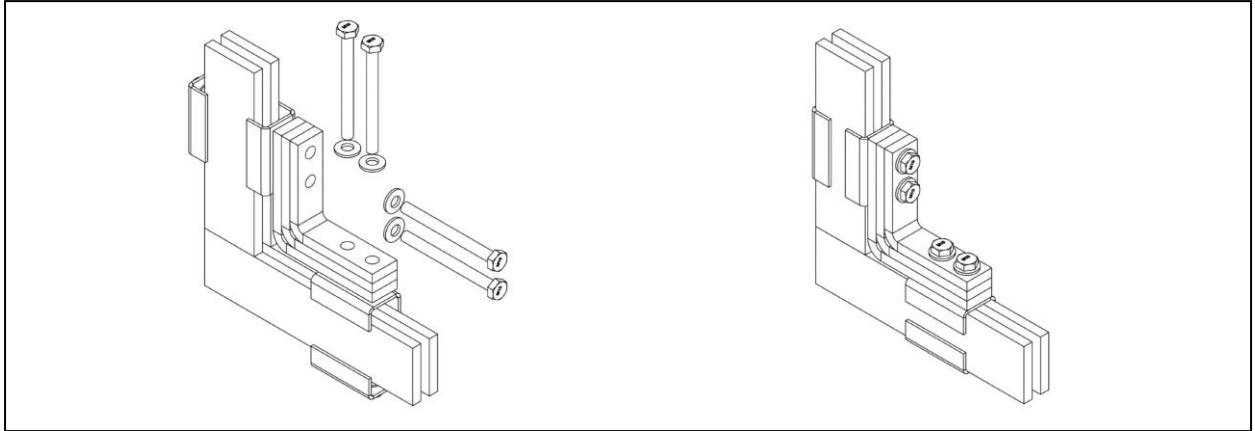

Figure 4.25 Transition Bus Connection – Traditional Fish Plates 2000A (2X80X10)

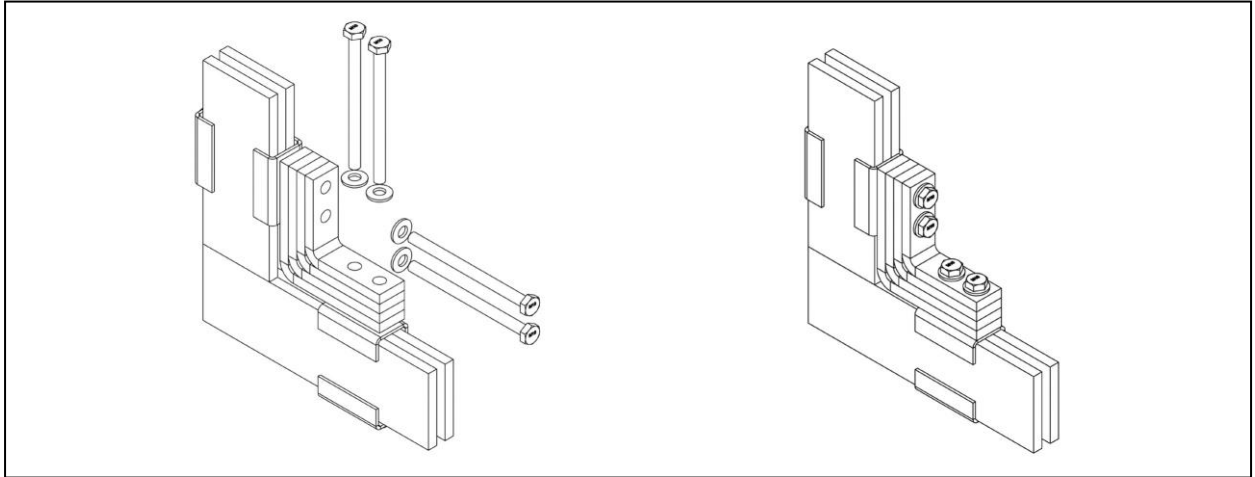
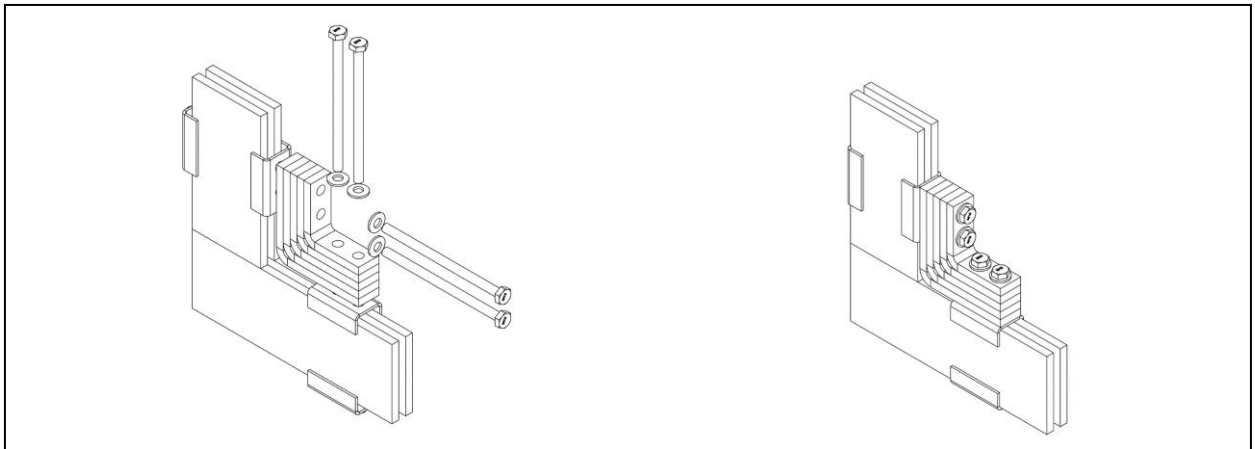

Figure 4.26 Transition Bus Connection – Traditional Fish Plates 2500A (2X100X10)



4.27

2500A (3X80X10)

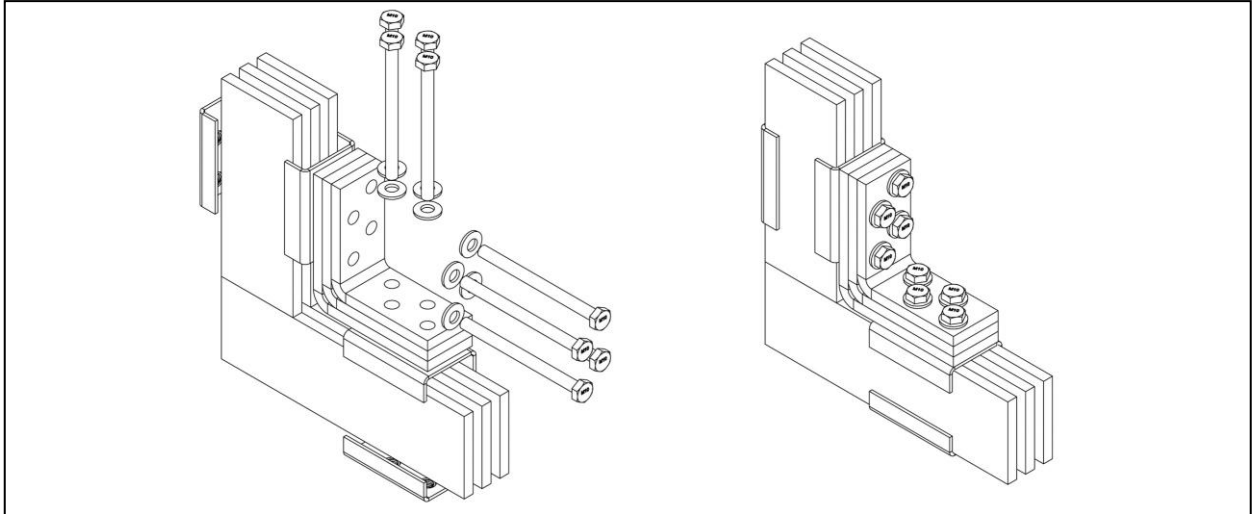
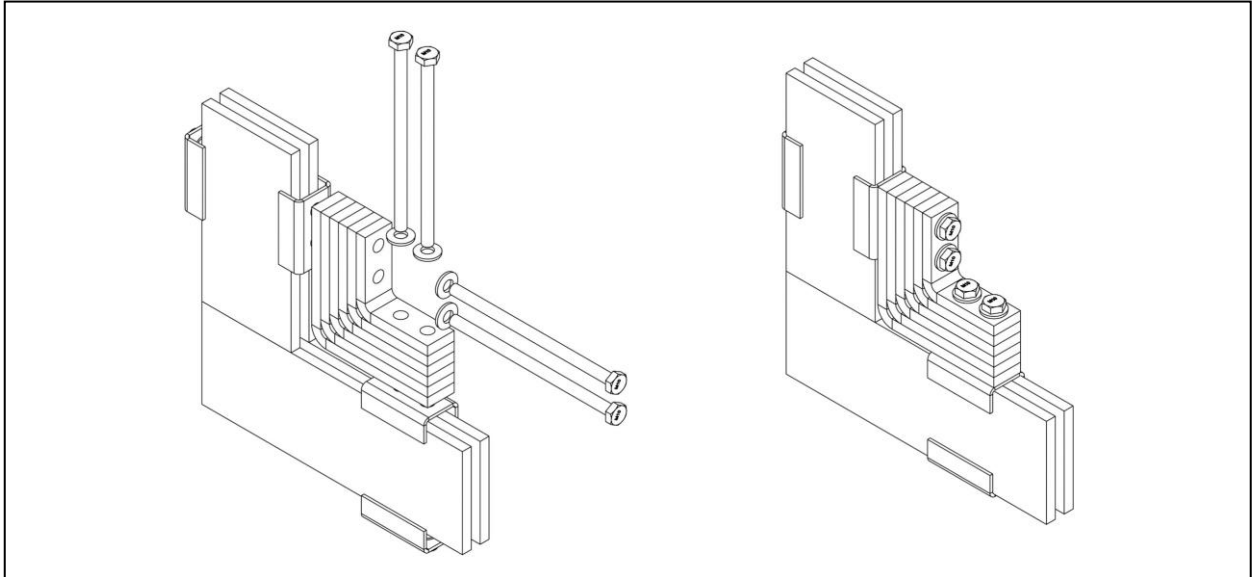

Figure 4.28 Transition Bus Connection – Traditional Fish Plates 3000A (2X100X10)



4.29

3000A (3X80X10)

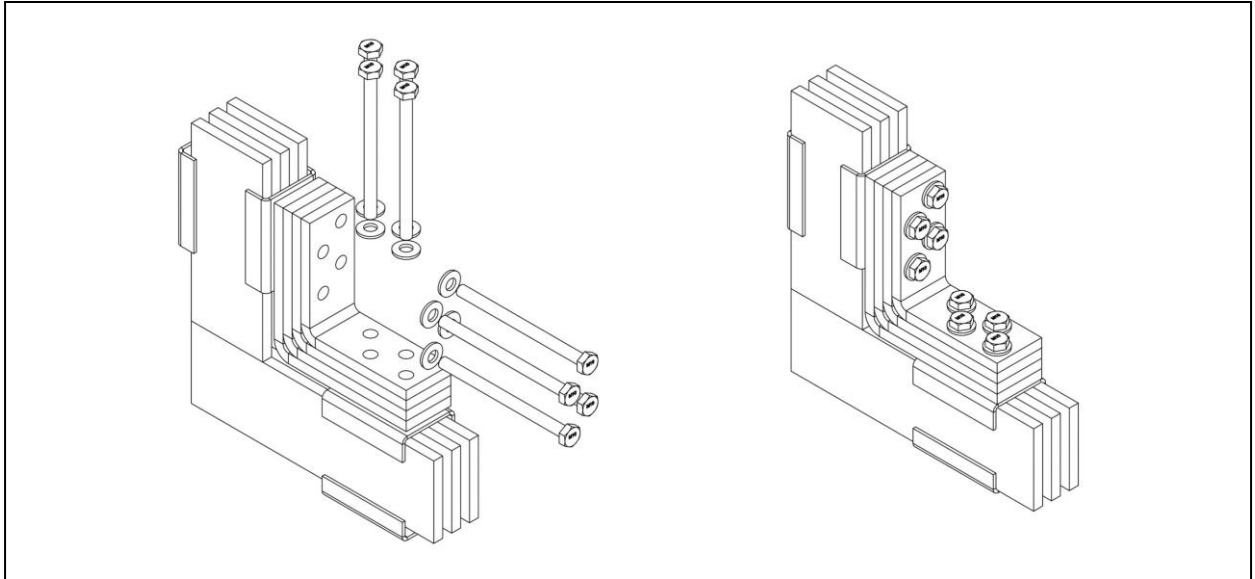
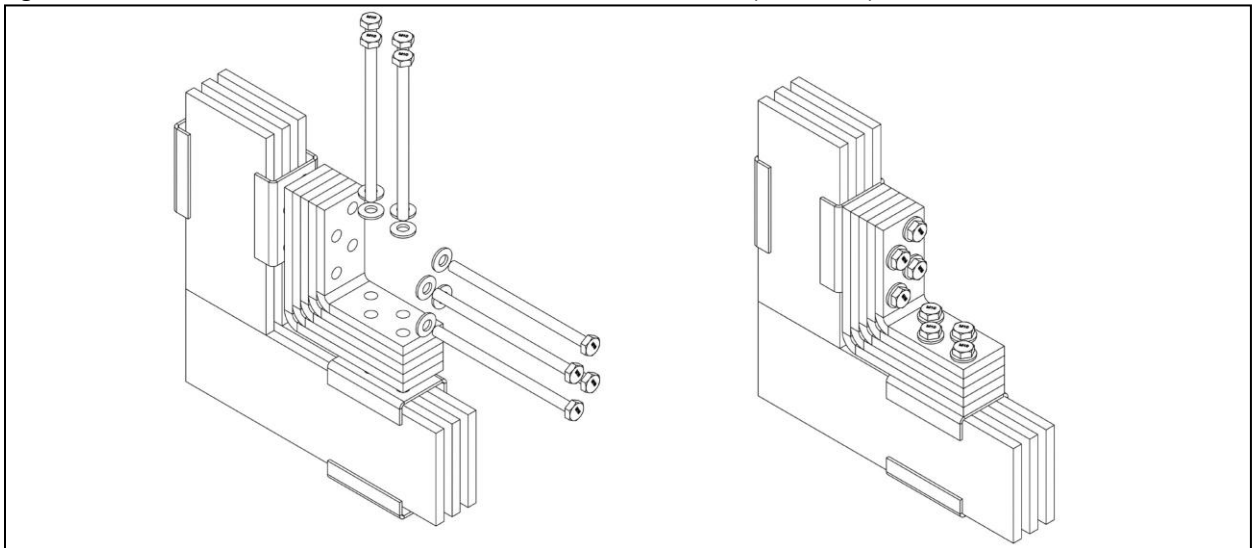

Figure 4.30 Transition Bus Connection – Traditional Fish Plates 4000A (3X100X10)



## 4.6.2 Ground Bus Connection

The Figure 4.31 on the next page provides a typical representation of the arrangement of adjoining ground bus at panel splits. Refer to [Typical Ground Layout](#) on page 8 and/or project specific drawings for ground bus location details based on the configuration of the switchboard (top vs bottom incoming/outgoing, front vs rear access and so on). When joining the ground bus, apply torque settings for M10 hardware as set forth in Table 7.1 on page 43.

4.31 Typical Ground Joining

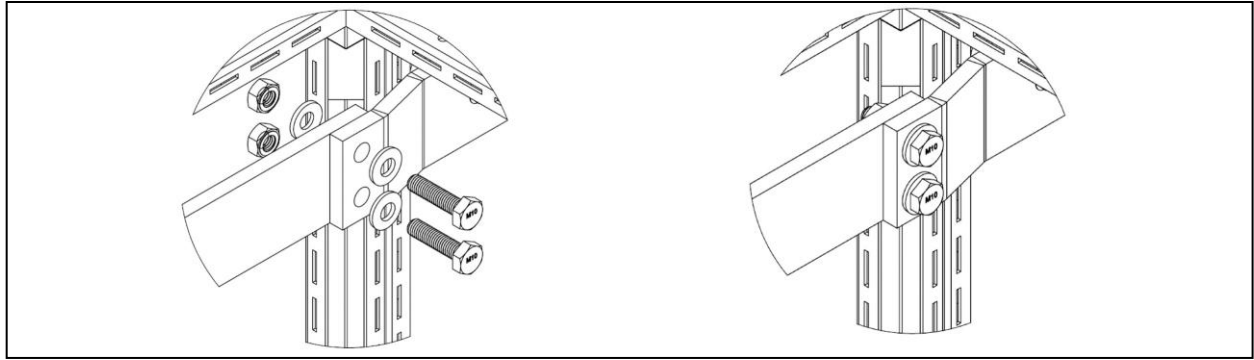

### 4.6.3 Cable Connections

Cable connections are used as the primary form of power entering and leaving the switchboard. Cable connections require mechanical or compression lugs to connect the cable to the provided field termination lug pads (see Figure 4.32 below).

**NOTE:** Vertiv not responsible for providing the lugs, but does supply the lug landing pads for mounting. Vertiv will supply standard lug pads for all amperages, custom pads can be supplied on a per project basis.

Refer [Typical Customer Connections](#) on page 5 for types or supplied documentation if custom pads are requested. Apply torque settings for hardware as set forth in [Table 7.1](#) on page 43.

Figure 4.32 Lug Types

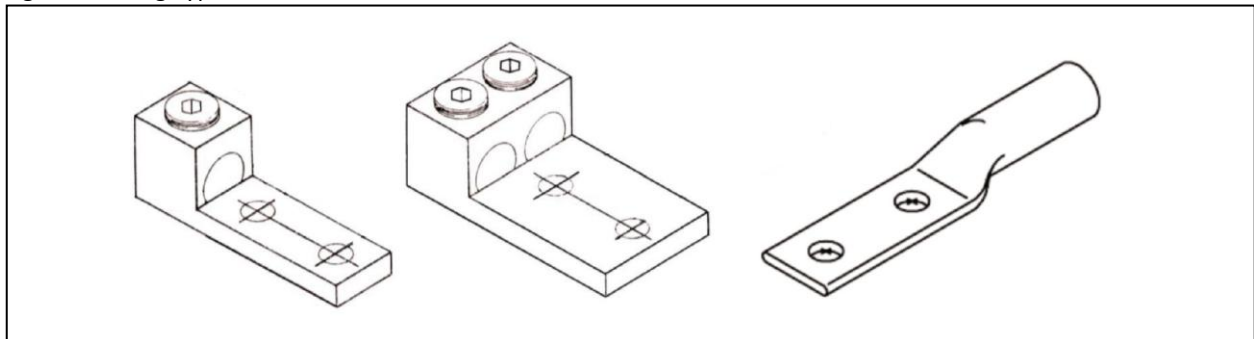

Cables may enter or exit through the top and/or bottom of the switchboard. These areas are identified with an aluminum gland plate on top or inside of the switchboard. Additional entry and exit locations can be used, these will be determined on a per project basis. Consult the manufacturer’s drawings for conduit/ glanding areas for the specific project.

Once the conduit and cable have been fixed to the switchboard, the cable should be bent in the sections provided. Bundle the cables and identify them by specific phase and neutral, if applicable. When bending the cable, make sure no insulation is forced permanently against a sharp metal edge, this could potentially cause damage. In most cases, cable supports should be present so that the cables can be secured.

The installer must strip the cables insulation to sufficiently fill the entire barrel of lugs being used. Ensure that no strands inside the cable are damaged and that all are of equal length before inserting into the lug. Do not strip off more insulation than required to fit into the lug, as exposed strands could compromise required spacings.

Mechanical lugs or compression lugs can be used as stated above. When using the different types of lugs, make sure they are being installed in the proper manner. Mechanical lugs use set screws for clamping onto the wire, where crimp lugs are physically crimped to the cable with an approved tool from the compression lug manufacturer. Once the lugs are fixed to the cable, install the lug onto the provided lug pads using required hardware. Torque the hardware based on the values in Table 7.1 on page 43.

## Lashing

Cable lashing is recommended, but not required. The installer is allowed to do cable lashing if desired. The process of lashing is laid out below.

Lashing should be performed by bundling the individual line cables and tap cables together using nominal 0.375 in. (9.525 mm) nylon rope (or rope having a minimum tensile strength of 2000 lbs (907.1847 kg)) at 6 in. (152.4 mm), and then after every 12 in. (304.8 mm), see Figure 4.33 below.

Figure 4.33 Typical Lashing Details

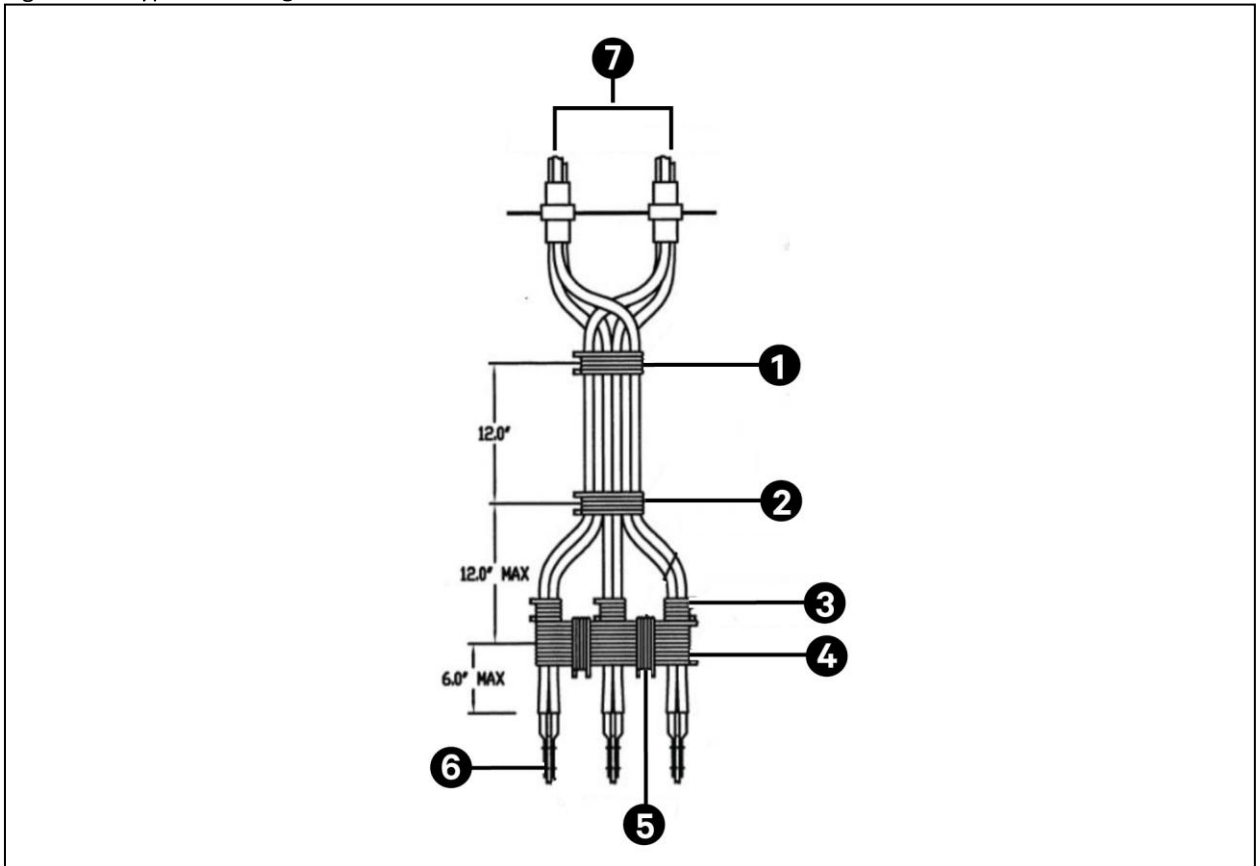

Item	Description
1	5 Wraps as required
2	5 Wraps
3	5 Wraps (3X)
4	10 Perimeter wraps

Item	Description
5	5 Wraps (2X)
6	Cable lugs (3X)
7	Roof or floor entrance

#### 4.6.4 Busway

A switchboard may have one or more busway flange connections. The switchboard can accept various manufacturer's busway flanges. The busway can feed the switchboard, be fed by the switchboard, or both. The switchboard uses internal risers, transition plates, and bus links to connect to each flange on a per project basis. The busway typically enters and exits the switchboard through the top. The switchboard should not be used to support the busway run. Adequate installation of the busway per the busway manufacturer should be implemented all the way up to the switchboard. Follow the instructions shipped with the busway for mounting and any switchboard manufacturer drawings provided.

The below images illustrate proper installation of an Vertiv panel flange, using M8 hardware. Front, side, and/or rear covers may need to be removed to access hardware on the underside of the gland plate. Apply torque settings for hardware as set forth in Table 7.1 on page 43. Size, amperage, material, and phasing orientation of the flange are determined on a per project basis. Joining busway sections together should be done so by following the busbar installation manual provided by the manufacturer.

Figure 4.34 Typical Installation of a Panel Flange

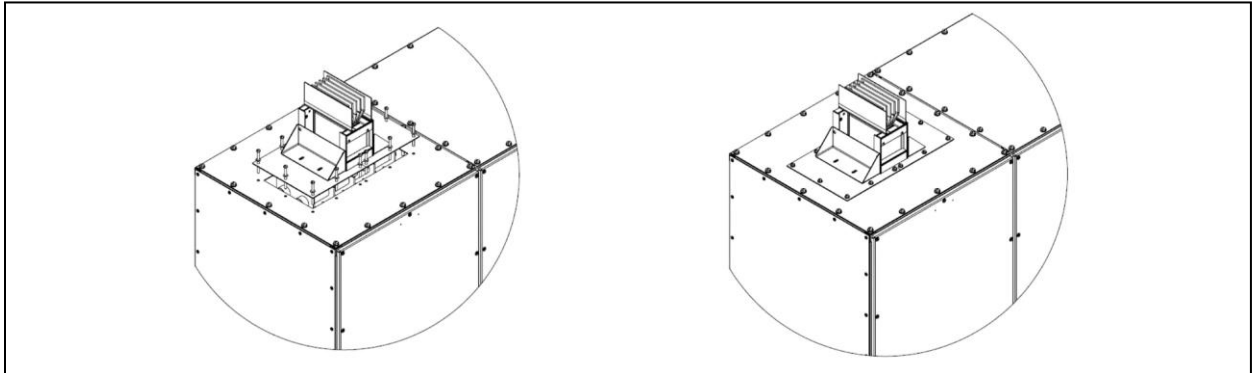

If a busway flange is required on a type 3R unit, then the sealing of the flange is critical. Once the internal connections are completed, the installer is solely responsible for sealing the connection between the flange and switchboard. It is up to the installer to use gasket or properly rated silicone to ensure a liquid tight seal. If the connection between the flange and switchboard is insufficient, the panel may leak and cause damage.

**NOTE:** Vertiv takes no liability for the panel leaking based on the installation of the flange.

## 5 Energization

### 5.1 Pre-Energization

Before energizing any switchboard, a comprehensive inspection should be performed.

Ensure of the following checks:

1. All the shipping splits are connected and secured to the floor.

2. All adjoining fish plates are installed and torqued.
3. The switchboard is clean and free from any dust, dirt, or contaminants.
4. All gland/conduit plates are installed and secured to the switchboard.
5. The switchboard is grounded appropriately.
6. All withdrawable air circuit breakers are installed.
7. All covers and doors are installed, closed, and locked, if applicable.

### **5.1.1 Pre-Energization Tests**

Prior to energization, the following tests must be performed on the switchboard, with all the breakers installed and closed, and all control fuses/circuit breakers removed or open.

- Continuity checks of the main power circuit (it is advised to use a high-resolution resistance tester and record the results, as these results can be compared during each service interval and any anomalies can be investigated).
- Insulation resistance test.
- 2.2 kV Hipot test.

Once these tests are complete, the switchboard can be returned to its normal state with all control fuses/circuit breakers installed or closed. The switchboard is now ready for energization.

This page intentionally left blank

5 Energization

## **6 Maintenance**

Maintenance is critical, but for trouble free operation and long service life of equipment, regular maintenance should be performed on the switchboard and carried out by competent, trained personnel wearing proper PPE. During maintenance, follow the local authority jurisdiction and/ or individual facility procedures to properly lockout/ tag out the equipment.

### **6.1 Setting Up a Maintenance Schedule**

- It is highly recommended to set a maintenance schedule for the switchboard.
- Note the usage of the equipment and determine how often maintenance should be performed.
- Before performing any maintenance make sure the power is turn off and every thing is de-energized.
- Ensure that OSHA approved solvents comply with local regulations are used for cleaning.
- The solvent should be non-flammable, with a threshold limit of 300 PPM or higher.

## 6.2 Maintenance Inspections

Maintenance inspections should be performed on the switchboard and accessories periodically, depending on the maintenance schedule established by the end user. Perform visual and physical inspections to ensure the working conditions of the equipment.

Below are the visual and physical inspections that should be performed.

1. Visual – Proper operation of all indicators, meters, and instruments.
2. Physical – All bolted covers are properly secured.
3. Visual – Proper operation of heaters and thermostats, if available.
4. Physical – Check all bolt connections to ensure the correct fitment. If discoloration or corrosion exist, then there may be an overheated connection.
5. Physical/Visual – Make sure all cables are tightly secured and supported.
6. Visual – Look for signs of wear and tear on control wiring. Wire should be replaced if uncertain.
7. Physical – Clean the equipment by wiping all areas with a clean cloth or the use of compressed dry air.
8. Physical/Visual – If an overhead lifting device is present and used, make sure the gear mechanism and rope are in tack and performing properly before lifting.

Other than stated above, maintenance should be carried out on all individual devices and instruments, according

to the specific maintenance requirements laid down by the manufacturer. This includes and is not limited to the low

voltage circuit breakers, instruments, indicators, meters, and any other possible components that are installed within the

equipment. 6 Maintenance

This page intentionally left blank

## 7 Torque Table

All mechanical parts within the equipment are assigned a torque value. The Table 7.1 below specifies the required torque values for each size of bolt, unless otherwise specified. All mechanical parts come pre-marked and torqued to the values below. If the hardware is not marked or specified below, then it is understood that hand tight capacity, which on average is 2 ft-lbs (3 Nm), is acceptable.

Table 7.1 Torque Values

Bolt Size	Standard (ft-lbs)	Metric (Nm)
M6	6	8
M8	16	22
0.375 in.		
M10	29	39
M12	40.5	55
0.5 in.		

### 7 Torque Table

This page intentionally left blank

## 8 Accessories

The primary accessory offered by Vertiv is an Over Head Lifting Device (OHLD).

- The OHLD is used to lift breakers from the floor or from a completely drawn out cradle.
- An internal winch with wire rope is used to provide the power for lifting.
- The device can travel the complete width of the switchboard lineup.
- Rails come with the OHLD and are mounted on the top of the switchboard, these rails have holes that allows for the OHLD to lock into place in the center of the section.
- The rails mount on the top of the device compartment to provide support to the entire lifting system.

Figure 8.1 Over Head Lifting Device

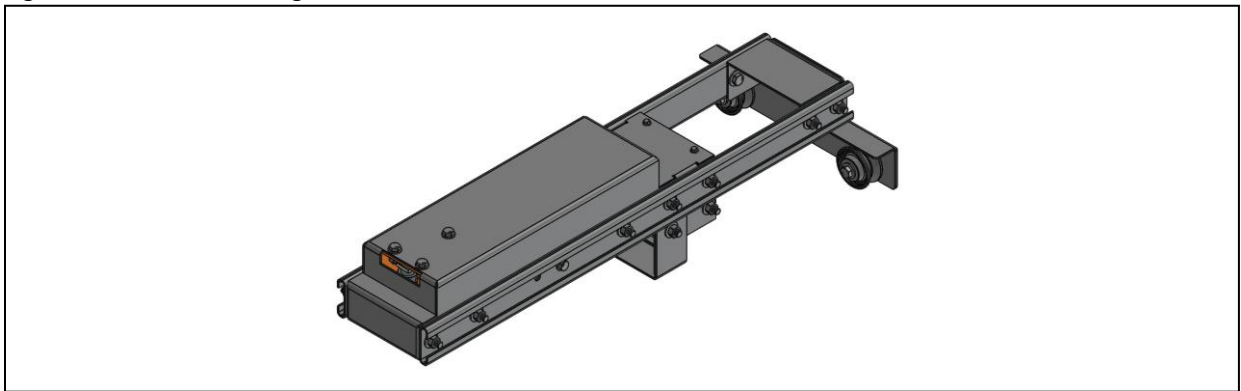
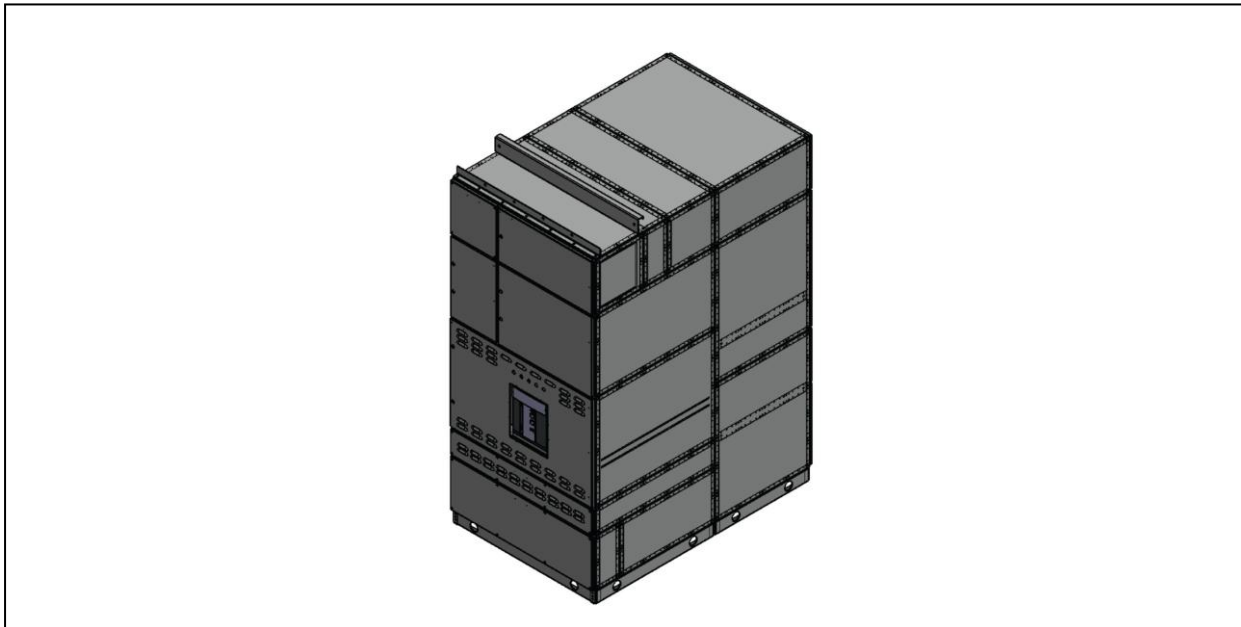

Figure 8.2 Section with OHLD Rails



## 8 Accessories

### 8.1 OHLD Installation

The OHLD device is shipped separately and must be attached to the lineup once the lineup is installed. Follow the below guidelines to help with the installation of the OHLD.

1. Remove the OHLD and rails from the shipment and unpackage them.

Figure 8.3 Packaged OHLD Accessories



2. Remove the bolts from the front cover and the front row of the second cover. These hole locations are used to mount the OHLD rails onto the lineup.

Figure 8.4 Bolt Removal

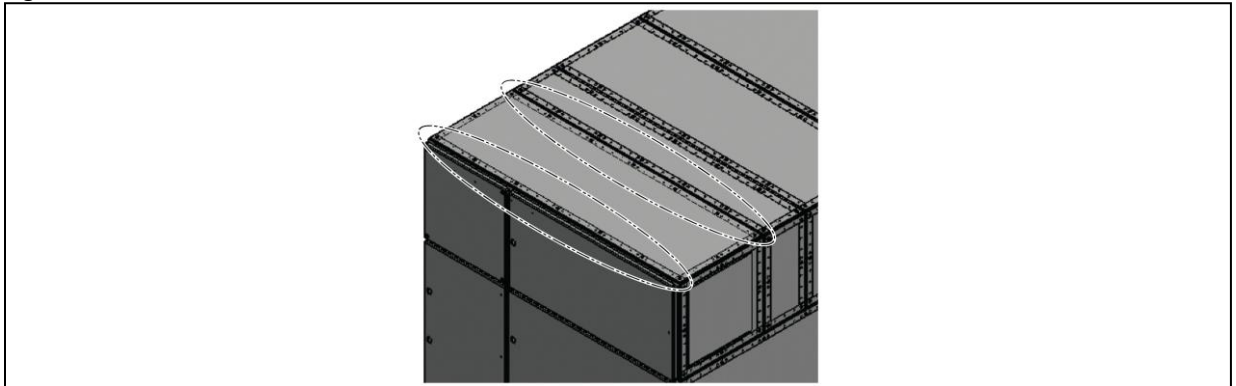

3. Mount the front and rear rail onto the top of the unit using the supplied hardware.

**NOTE:** Countersunk M8 bolts are used to fix the front rail, to allow for the OHLD to glide across.

Figure 8.5 Typical OHLD Rails

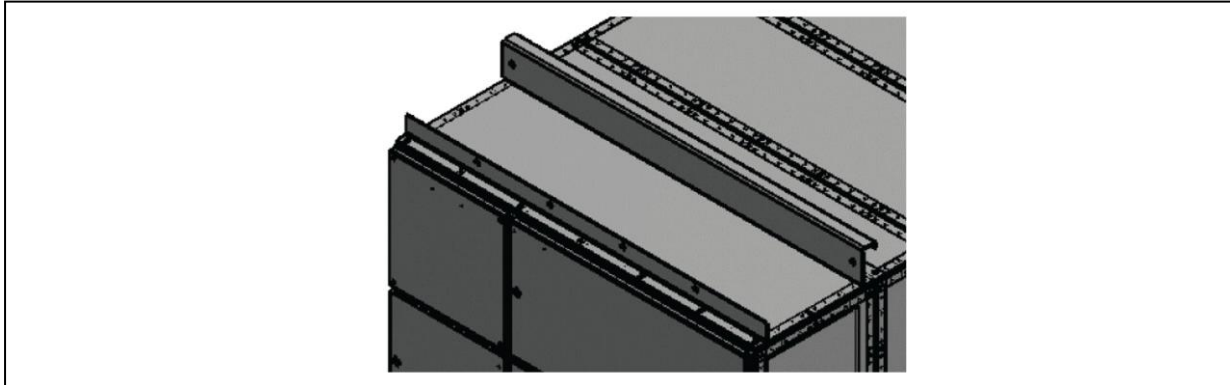

4. Position the OHLD onto the prongs of a forklift and raise up to the position of the rails.
5. Align the grooves of the wheels with the front rail and behind the rear rail and slide it on.

Figure 8.6 Side View of OHLD on Rails

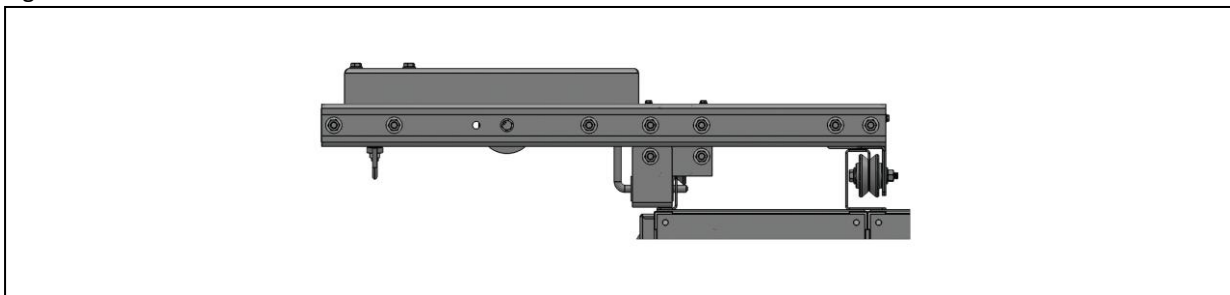

6. Install stoppage bolts in the rear rail, at the far left and right of the end sections if the movement of the OHLD is correct.

Figure 8.7 End Bolt Locations

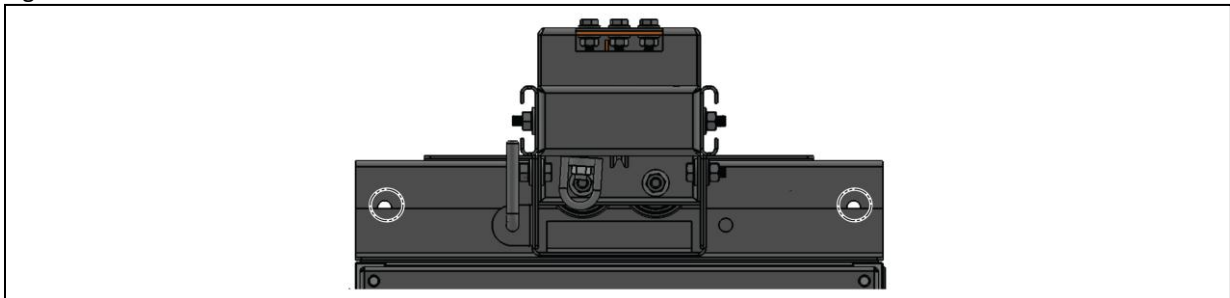

## 8.2 OHLD Operation

- While operating the OHLD, specific details should be observed and ensure it will operate as intended.
- Before using the OHLD, make sure it is set correctly on the track and properly leveled.
- Make sure at least four to five wraps of the wire rope are around the drum before lifting, and the wire rope is free of any knots or kinks.
- The OHLD should only be used to lift breakers. For safety purposes make sure never walk or stand under the OHLD device as it is lifting or holding a circuit breaker.

## 8 Accessories

### **Warranties and Liabilities**

This manual does not imply any understandings, agreements, representations, or warranties, other than what is specifically set forth by an existing contract between purchaser and seller. Any such contract will state the entire obligation of the seller. The manual shall not become a part of or modify any possible agreement, commitment, or relationship between the two parties.

This manual is based solely on Vertiv experience with the switchboard including all information, recommendations, descriptions, and safety notions within this document. Thus, anything in this manual shall not be considered all inclusive or covering all contingencies.

No warranties, expressed or implied, including warranties of fitness for a particular purpose or merchantability, or warranties arising from course of dealing or usage of trade, are made regarding the information, recommendations, descriptions, and safety comments contained herein.

In no event will Vertiv be responsible to the purchaser or user in contract, in tort (including negligence), strict liability or otherwise for any special, indirect, incidental or consequential damage or loss whatsoever, including but not limited to damage to or loss of use of equipment, plant or power system, cost of capital, loss of profits or revenue, cost of replacement power, additional expenses in the use of existing power facilities, or claims against the purchaser or user by its customers resulting from the use of information, recommendations, descriptions and safety comments contained herein.

# Appendices

## Appendix A: Technical Support and Contacts

### A.1 Technical Support/Service in the United States

Vertiv Group Corporation

24x7 dispatch of technicians for all products.

1-800-543-2378

Vertiv™ Powerbar Products

Europe - +44(0) 2835 3030

USA - +1 864 375 1757

UAE - +971 488 64062

### A.2 Locations

United States Vertiv Headquarters

505 N Cleveland Ave

Westerville, OH 43082

Europe

Via Leonardo Da Vinci 8 Zona Industriale Tognana

35028 Piove Di Sacco (PD) Italy

Asia

7/F, Dah Sing Financial Centre

3108 Gloucester Road, Wanchai

Hong Kong

## Appendix B: Submittal Drawings

Submittal drawings referenced in this document are listed below and are presented in the order as mentioned within this document.

Table 9.1 Submittals

Submittal Number	Title
DPN003332, Rev4	UL891 Switchboard Communication Connection Diagram for Cooling Units to UL891 Switchboard Panel
DPN005190, Rev0	Vertiv WSN Wireless Application Remote Mounting and Kit Antenna
DPN003318, Rev2	UL891 Switchboard Cabinet Dimensional Data Wall Mount

